

Content

	Nail - plates	2 - 6
	Connector plates	6 - 14
	Angle brackets	14 - 31
	Bracing straps	31 - 35
	Joist hangers	36 - 43
	Anchor straps	43 - 59
	Circular dowels (Bulldog)	60 - 61
	Anchor column shoes	61 - 66
	Connecting materials	67 - 68
	Other fittings	69 - 71

01 - 01 NAIL PLATE BV 10

width $W = 24, 36, 54, 72, 108, 144, 180, 216$ mm
length $L = 15 \times n$, ($n = \text{integer}$) mm
material thickness $T = 1$ mm

ordering example :
nail plate BV 10 01-01 $W \times L$

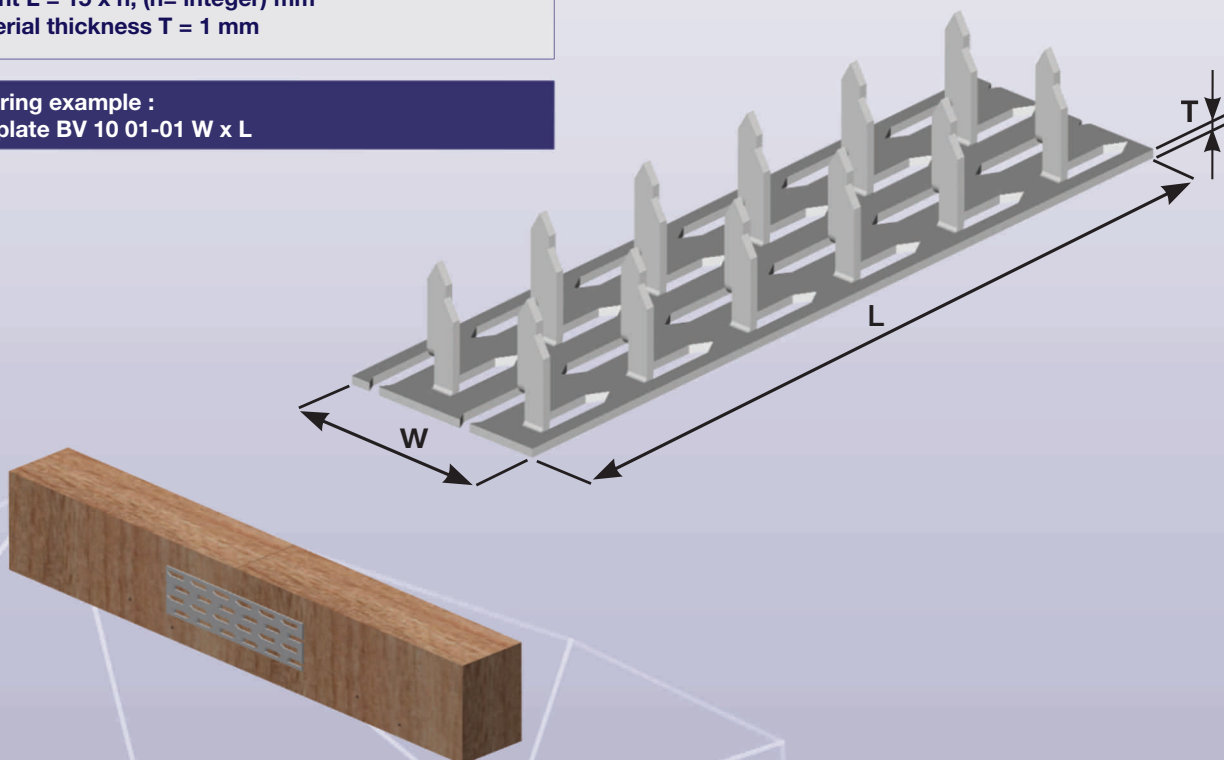

01 - 02 NAIL PLATE BV 15

width $W = 35, 56, 70, 84, 105, 126, 140, 175, 210, 280$ mm
length $L = 21 \times n$, ($n = \text{integer}$) mm
material thickness $T = 1,5$ mm

ordering example :
nail plate BV 15 01-02 $W \times L$

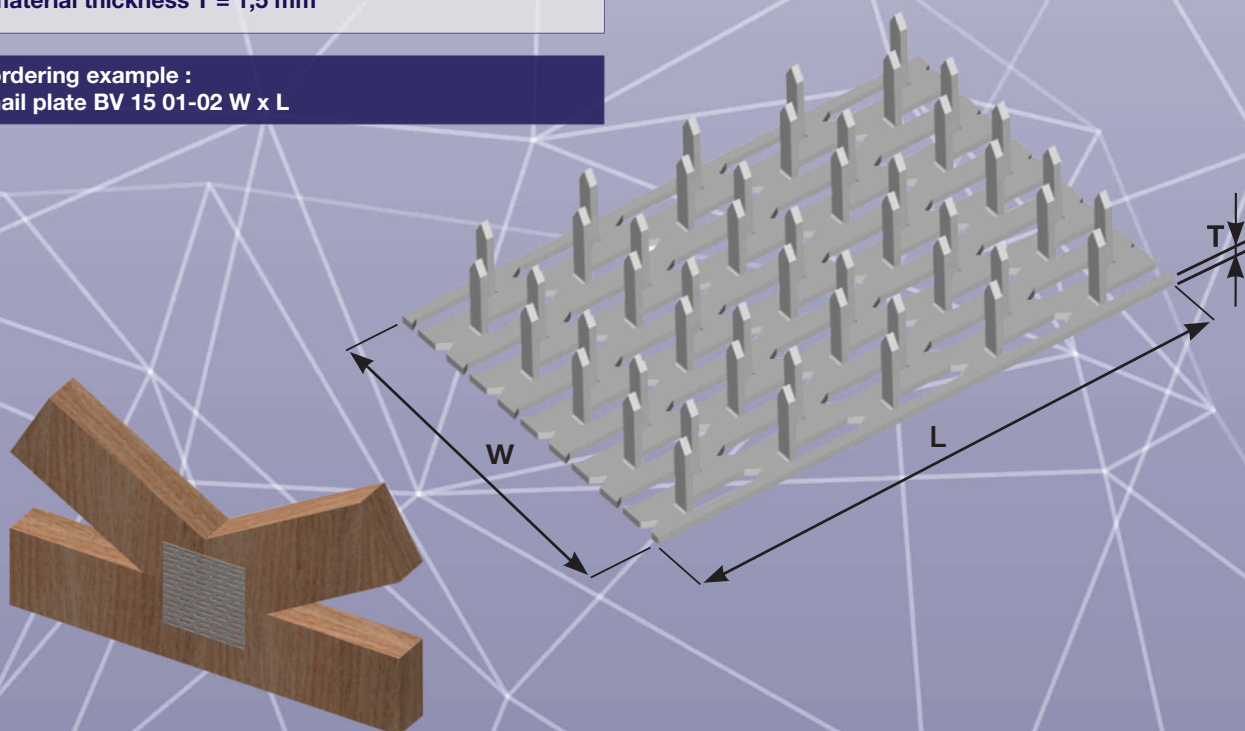

NAIL PLATE BV 20 01 - 03

width $W = 60, 70, 80, 100, 110, 120, 140, 160, 200, 240, 280$ mm
length $L = 33 \times n$, ($n = \text{integer}$) mm
material thickness $T = 2$ mm

ordering example :
nail plate BV 20 01-03 $W \times L$

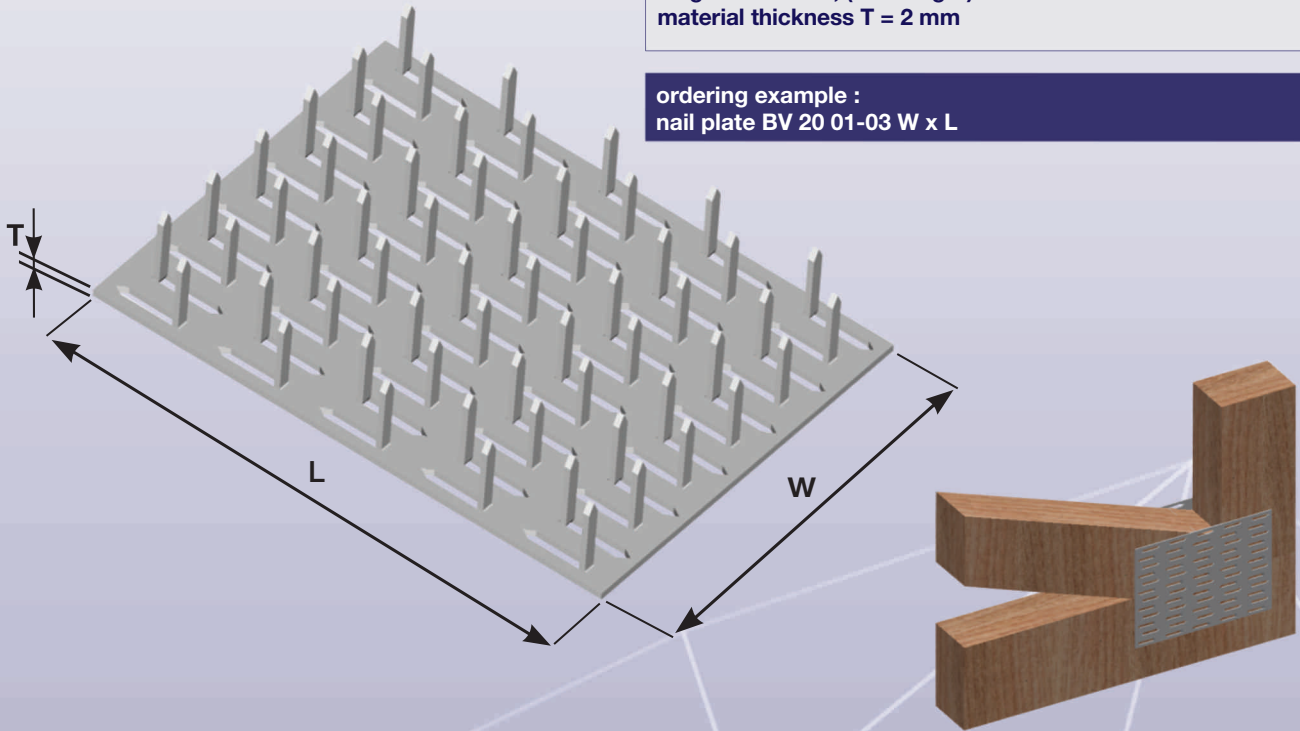

NAIL PLATE CORNER BV 15 01 - 05

width $W = 42, 63, 84, 105$ mm
length $L = L1 + L2 = 140, 175, 210, 280$ mm
material thickness $T = 1,5$ mm

ordering example :
nail plate corner BV 15 01-05 $W \times L$

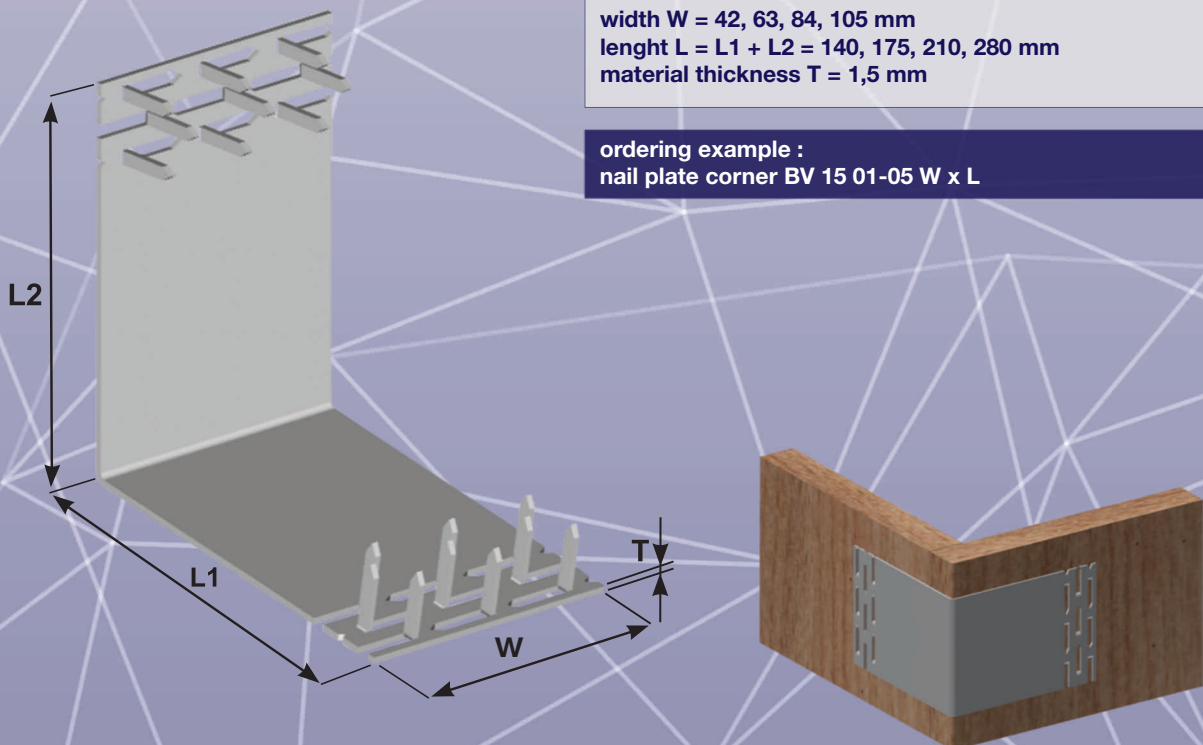

01 - 06 NAIL PLATE CORNER BV 20

width $W = 66, 99, 132$ mm
length $L = L1 + L2 = 160, 200, 240, 280$ mm
material thickness $T = 2$ mm

ordering example :
nail plate corner BV 20 01-06 $W \times L$

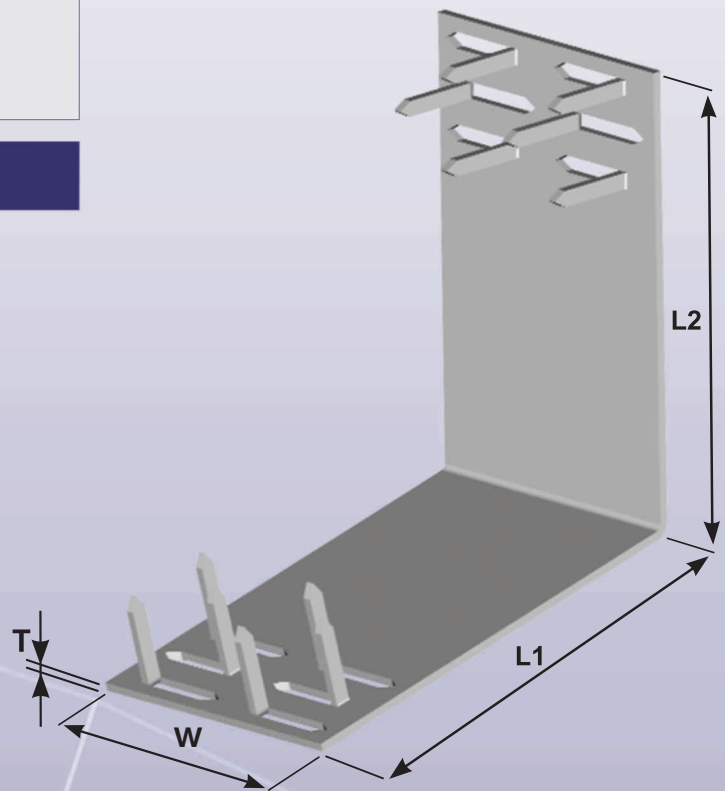
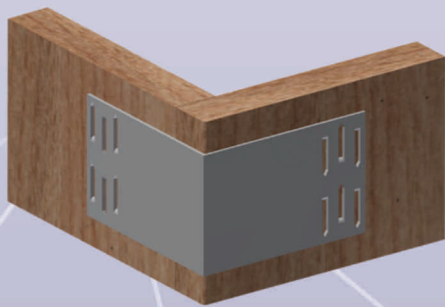

01 - 07 NAIL PLATE SYMMETRICAL BV 15/O

width $W = 35, 56, 70, 84$ mm
length $L = 21 \times n$, ($n = \text{integer}$) mm
material thickness $T = 1,5$ mm

ordering example :
nail plate corner BV 15/O 01-07 $W \times L$

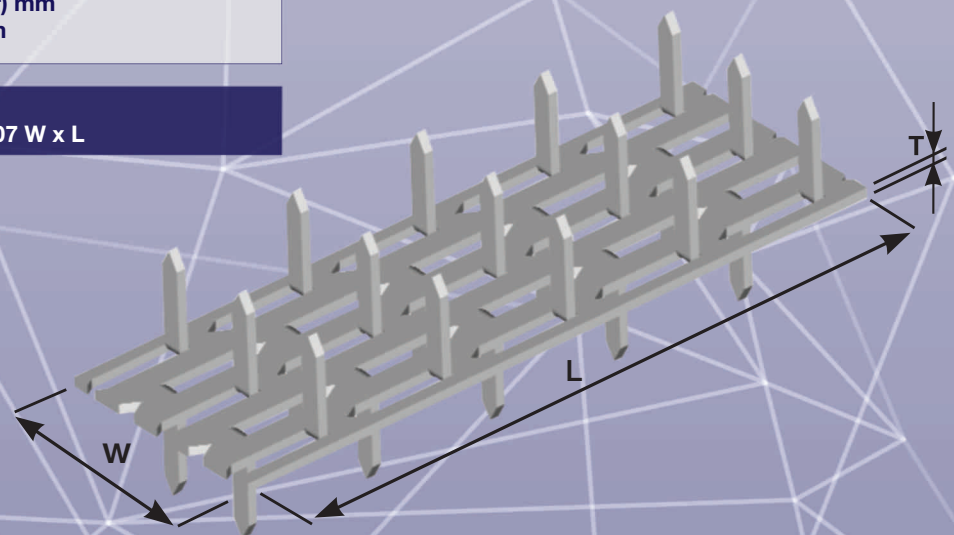
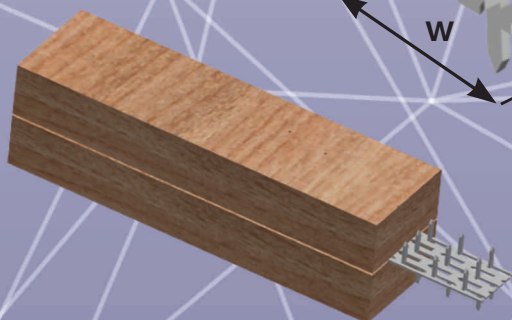

NAIL PLATE BV20/stainless 01 - 08

width $W = 60, 70, 80, 110, 120, 140, 160, 200, 240$ mm
length $L = 33 \times n$, ($n = \text{integer}$) mm
material thickness $T = 2$ mm

ordering example :
nail plate BV 20/stainless 01-08 $W \times L$

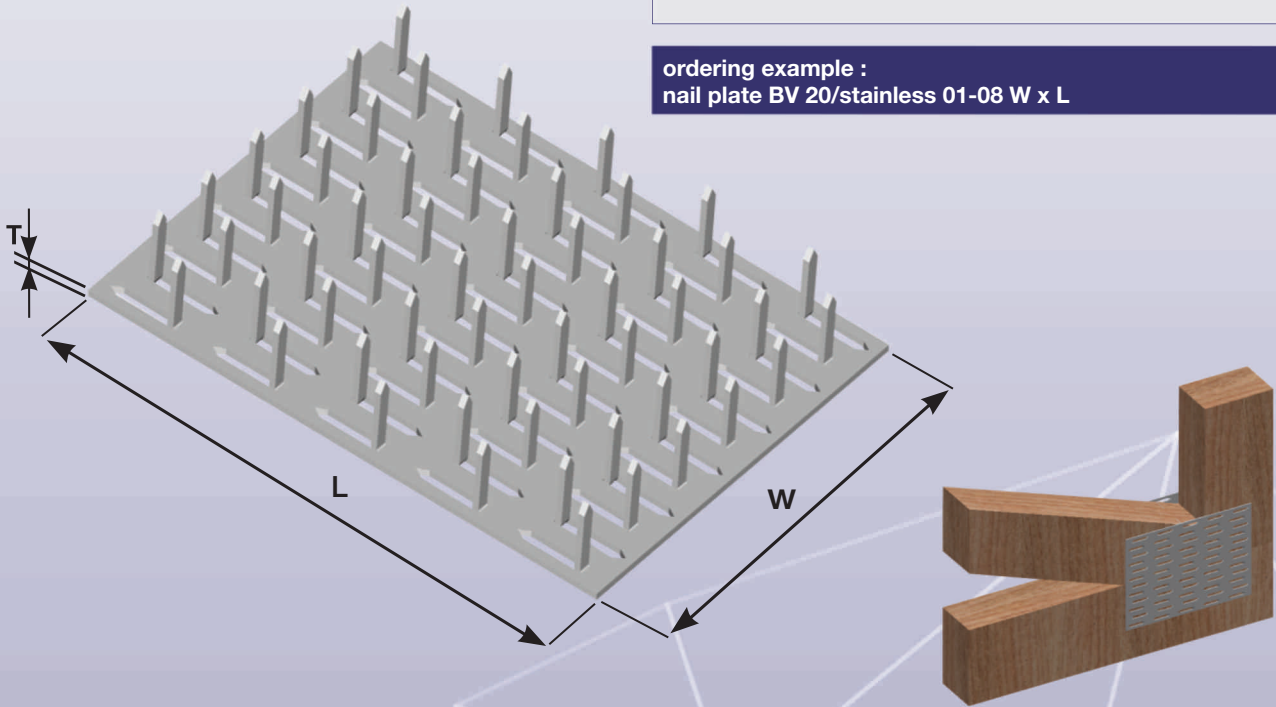

NAIL PLATE BV 11 01 - 10

width $W = 24, 36, 54, 72, 108, 144, 180, 216$ mm
length $L = 15 \times n$, ($n = \text{integer}$) mm
material thickness $T = 1$ mm

ordering example :
nail plate BV 11 01-10 $W \times L$

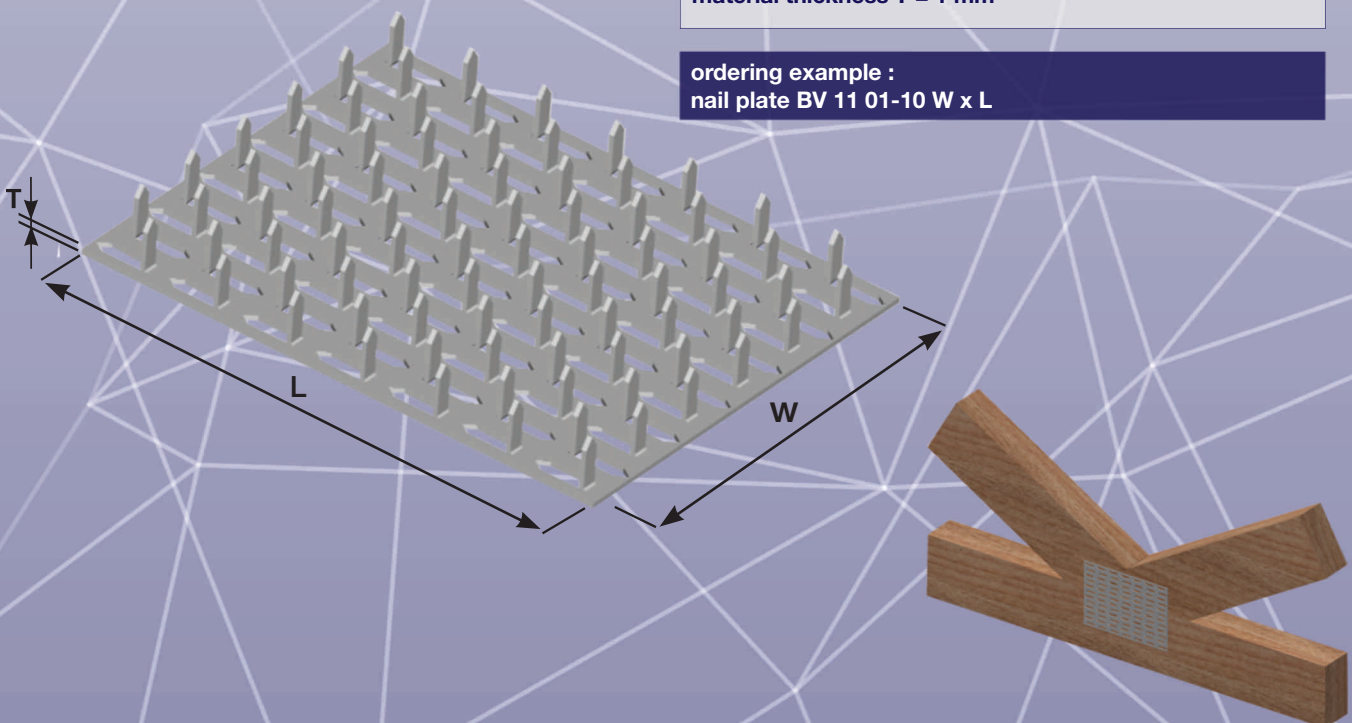

01 - 12 NAIL PLATE BV 16

width $W = 70, 80, 100, 110, 120, 140, 160, 200, 240, 280$ mm
length $L = 33 \times n$ (integer) mm
material thickness $T = 1,5$ mm

ordering example :
nail plate BV 16 01-12 $W \times L$

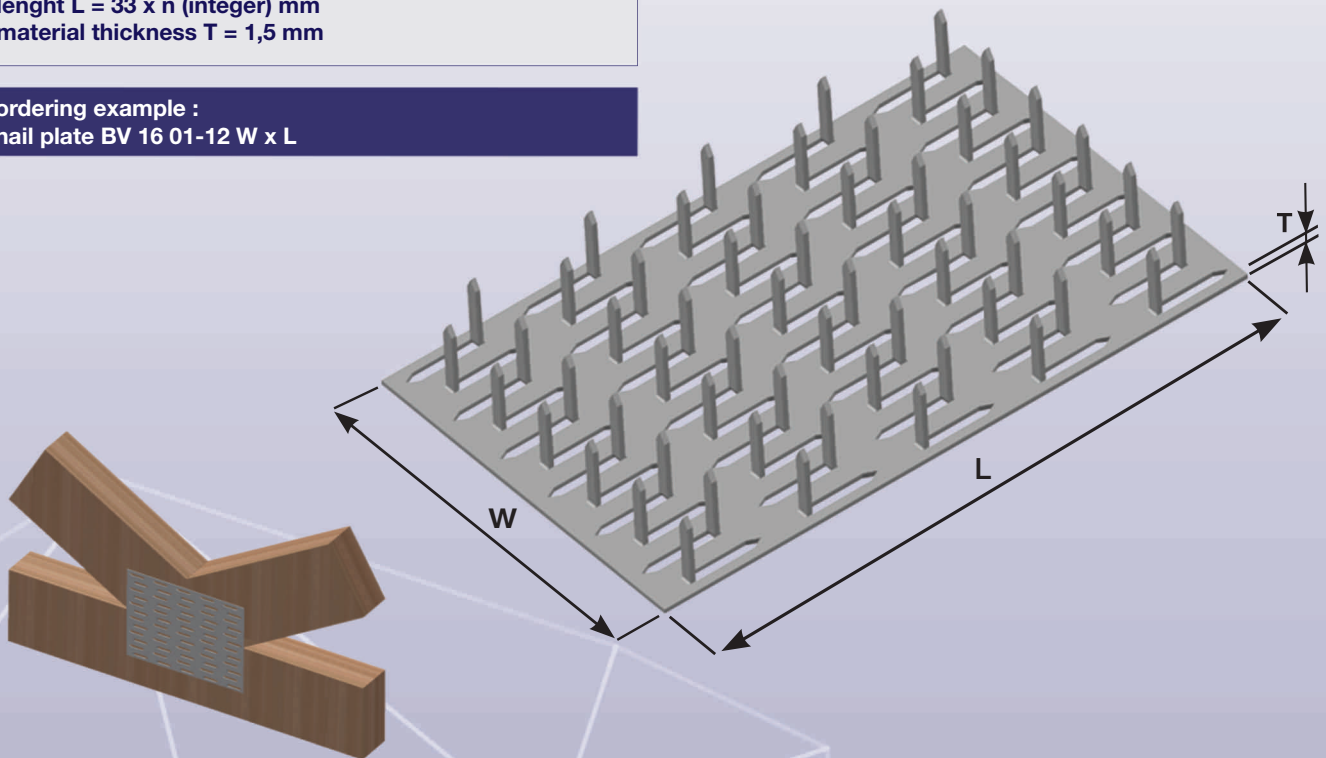

03 - 01 CONNECTING PLATE BV/DS

width $W = 40, 60, 80, 100, 120, 140, 160, 200, 240$ mm
length $L = n \times 40$ mm
material thickness $T = 2$ mm

ordering example :
connecting plate BV/DS 03-01 $W \times L$

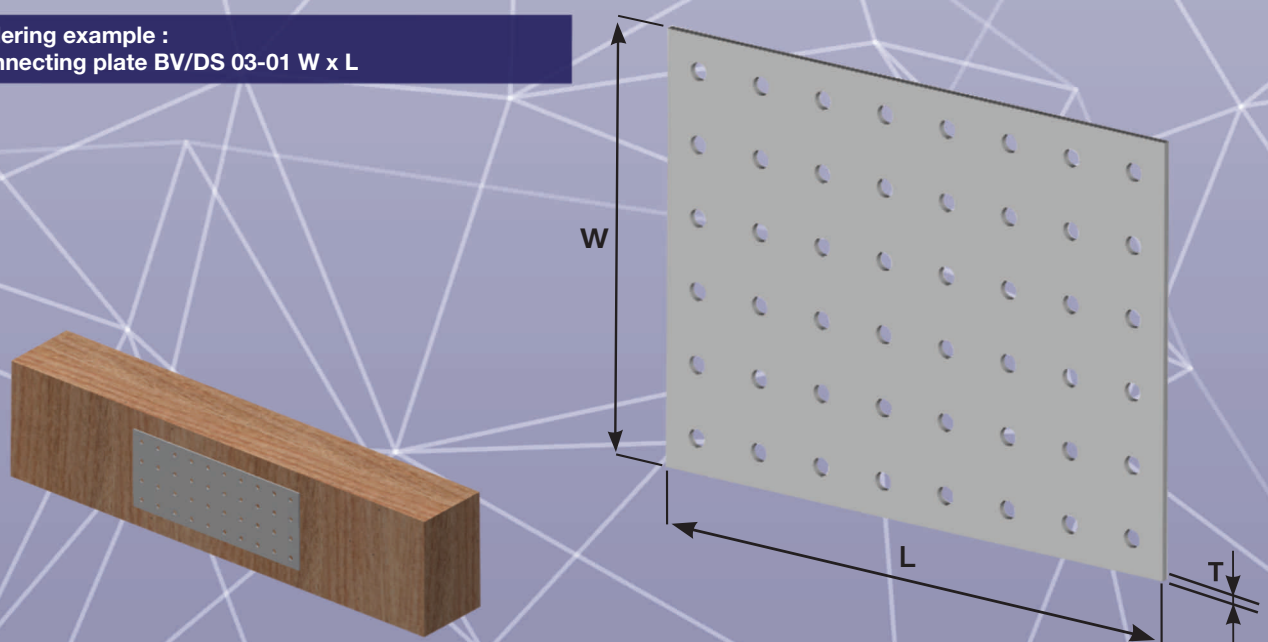

CONNECTING PLATE SKEWED 1x BV/DSZ

03 - 02

width $W = 80, 100, 120, 140, 160, 200, 240$ mm
width $W1 = \text{max. } W$ mm
material thickness $T = 2$ mm
length $L = n \times 40$ mm
length $L1 = \text{max. } L$ mm

ordering example :
connecting plate skewed 1x BV/DSZ 03-02 $W \times W1 \times T \times L \times L1$

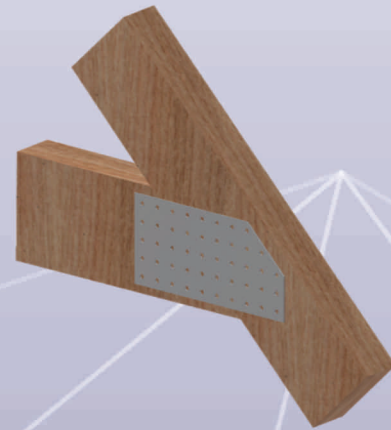
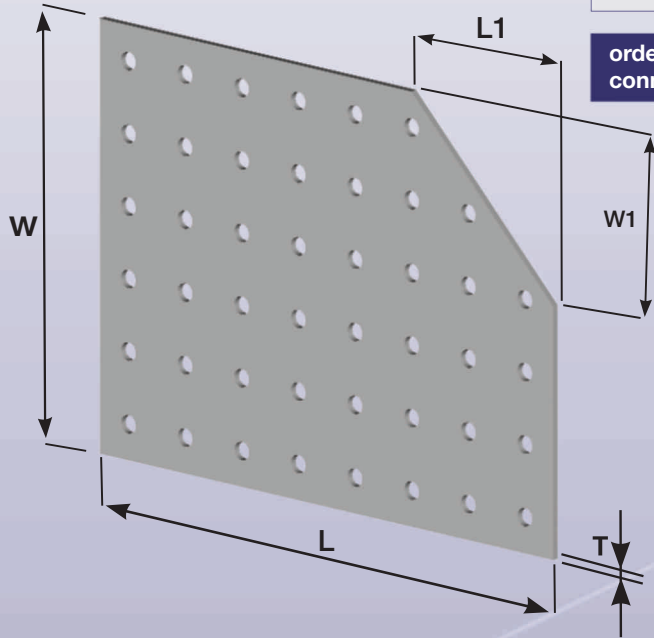

CONNECTING PLATE SKEWED 2x BV/DSZ

03 - 03

width $W = 80, 100, 120, 140, 160, 200, 240$ mm
width $W1 = \text{max. } W$ mm
material thickness $T = 2$ mm
length $L = n \times 40$ mm
length $L1 = \text{max. } L/2$ mm

ordering example :
connecting plate skewed 2x BV/DSZ 03-03 $W \times W1 \times T \times L \times L1$

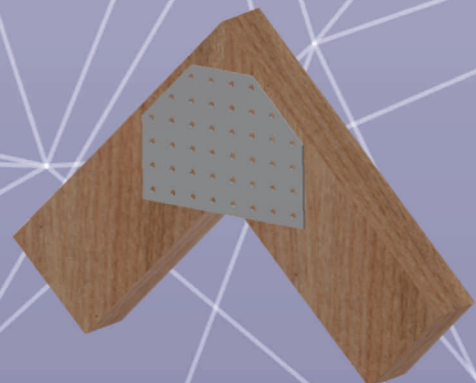
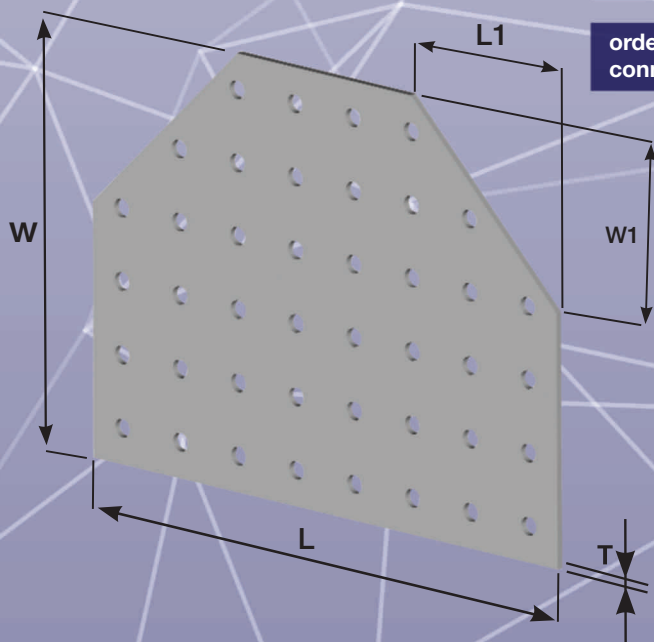

03 - 04 TRUSS CONNECTOR BV/SV

width $W = 160$ mm
length $L = 540$ mm
material thickness $T = 2$ mm

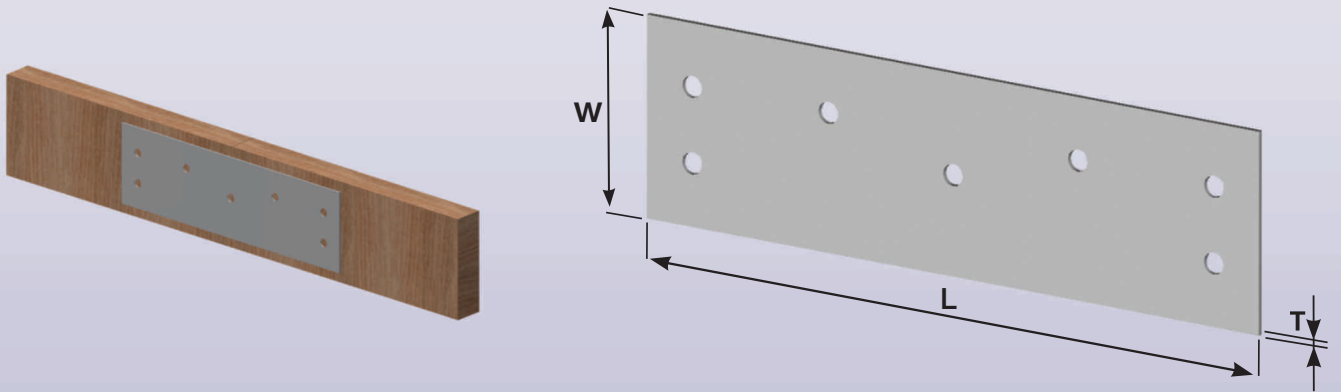

03 - 05 TRUSS CONNECTOR BV/SV

width $W = 160$ mm
length $L = 620$ mm
material thickness $T = 2$ mm

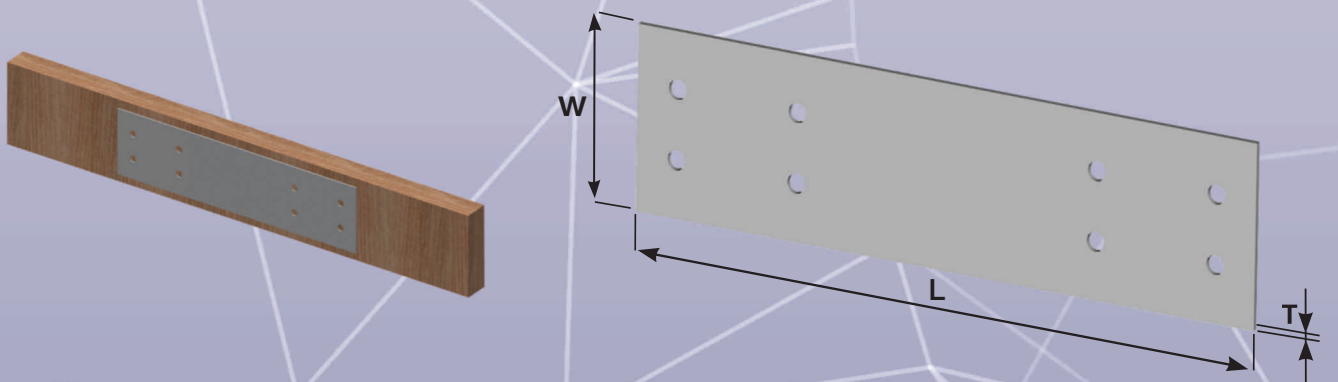

03 - 06 TRUSS CONNECTOR BV/SV

width $W = 160$ mm
length $L = 780$ mm
material thickness $T = 2$ mm

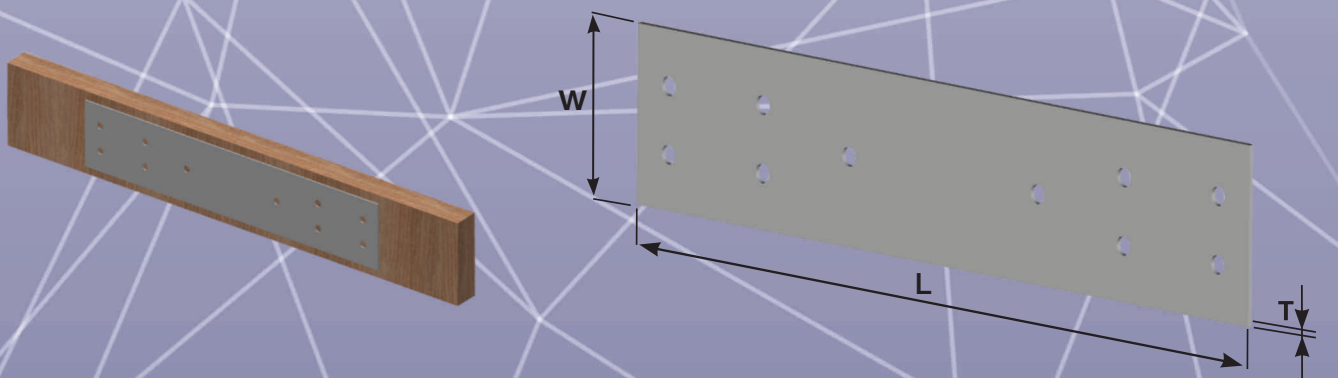

CONNECTING PLATE BV/DS 03 - 07

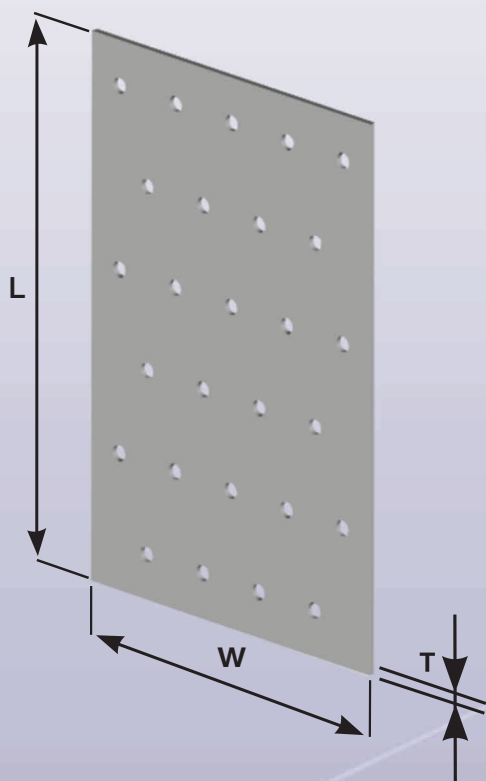

width $W = 80, 120, 140, 160, 200, 240$ mm
length $L = n \times 60$ mm
material thickness $T = 2$ mm

ordering example :
connecting plate BV/DS 03-07 $W \times L$

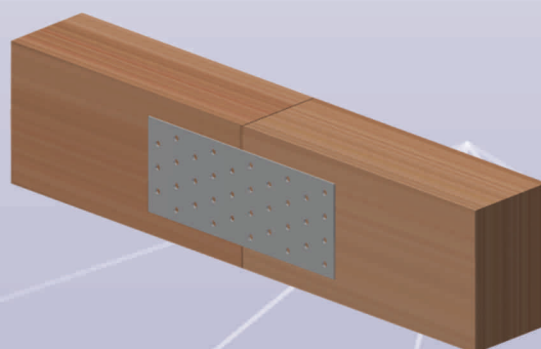

CONNECTING PLATE BV/DS 03 - 08

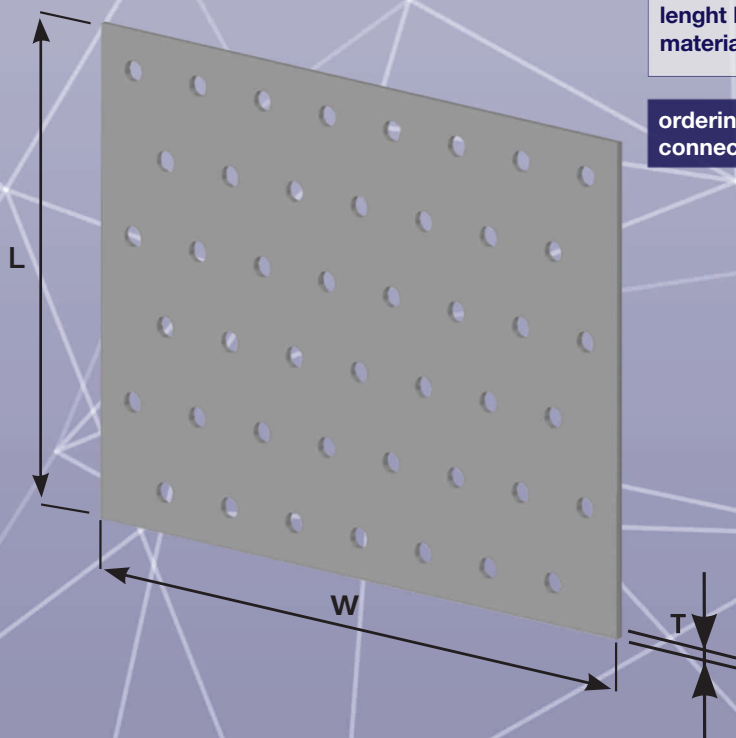

width $W = 40, 60, 80, 100, 120, 140, 160, 200, 240, 280$ mm
length $L = n \times 40$ mm
material thickness $T = 2$ mm

ordering example :
connecting plate BV/DS 03-08 $W \times L$

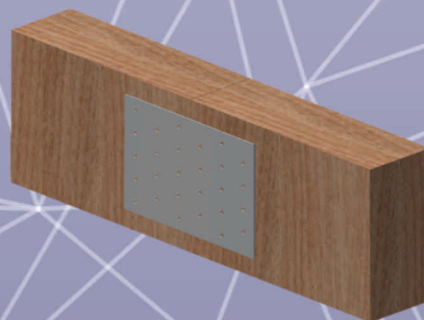

03 - 21 CONNECTING PLATE BV/DS

width $W = 40$ mm
length $L = 100, 140, 180, 220, 260$ mm
material thickness $T = 3$ mm

ordering example :
connecting plate BV / DS 03-21 / L

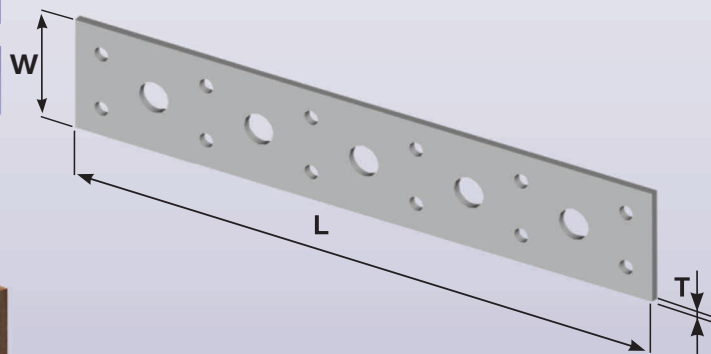
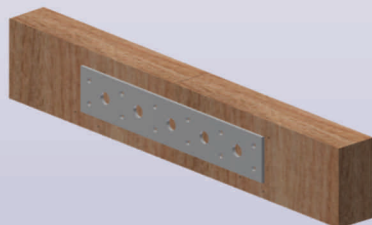

03 - 29 CONNECTOR 35 x 100 x 2

width $W = 35$ mm
length $L = 100$ mm
material thickness $T = 2$ mm

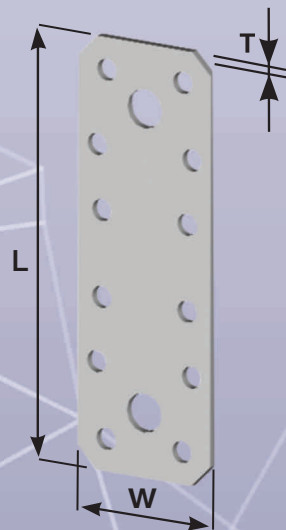
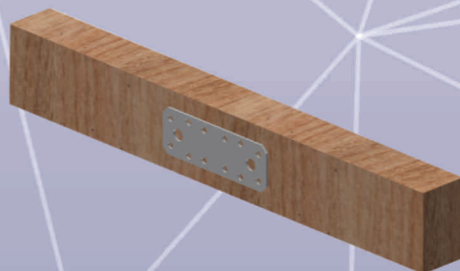

03 - 30 CONNECTOR 45 x 120 x 2

width $W = 45$ mm
length $L = 120$ mm
material thickness $T = 2$ mm

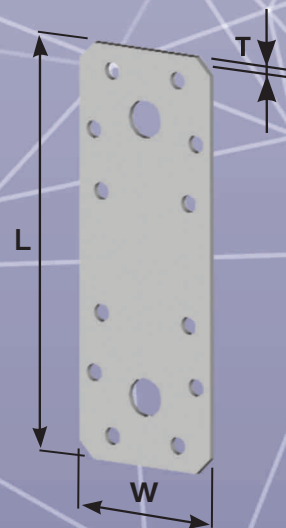
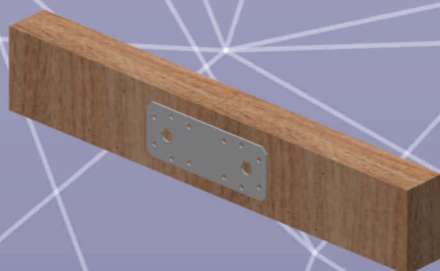

CONNECTOR 55 x 140 x 2 03 - 31

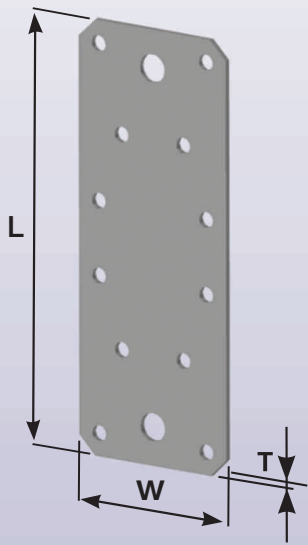

width $W = 55$ mm
length $L = 140$ mm
material thickness $T = 2$ mm



CONNECTOR 65 x 177 x 2,5 03 - 32

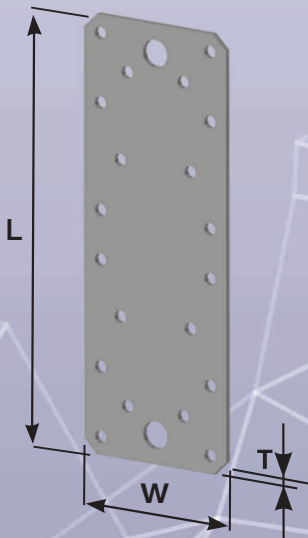

width $W = 65$ mm
length $L = 177$ mm
material thickness $T = 2,5$ mm

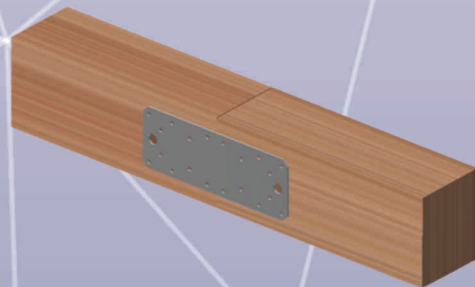

CONNECTOR 90 x 200 x 3 03 - 33

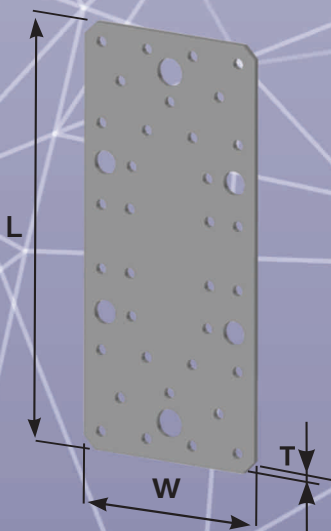

width $W = 90$ mm
length $L = 200$ mm
material thickness $T = 3$ mm

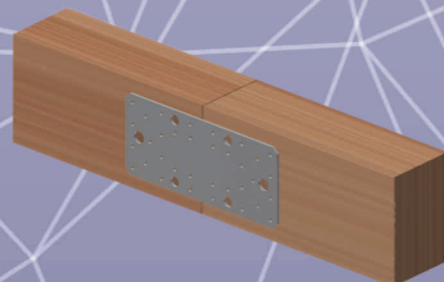

03 - 34 CONNECTOR BV/S 70

width $W = 30, 40, 50, 60, 70, 80, 90, 100, 110, 120, 130, 140$ mm
length $L = 70$ mm
material thickness $T = 1,5$ mm

ordering example :
connector BV/S 70 03-34/W

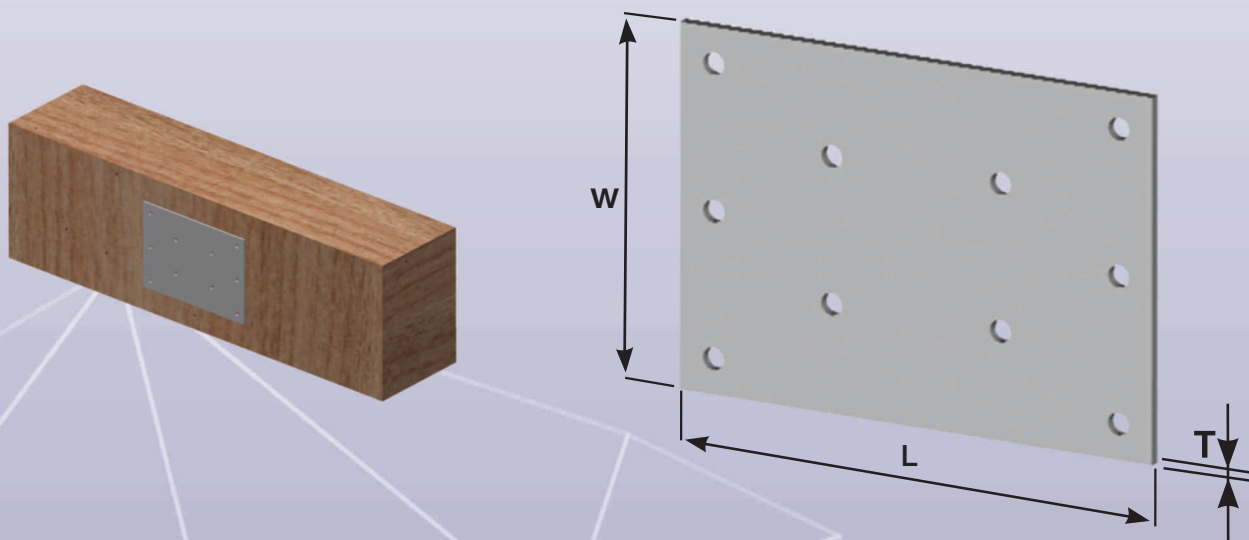

03 - 35 CONNECTOR BV/S 105

width $W = 30, 40, 50, 60, 70, 80, 90, 100, 110, 120, 130, 140$ mm
length $L = 105$ mm
material thickness $T = 1,5$ mm

ordering example :
connector BV/S 105 03-35/W

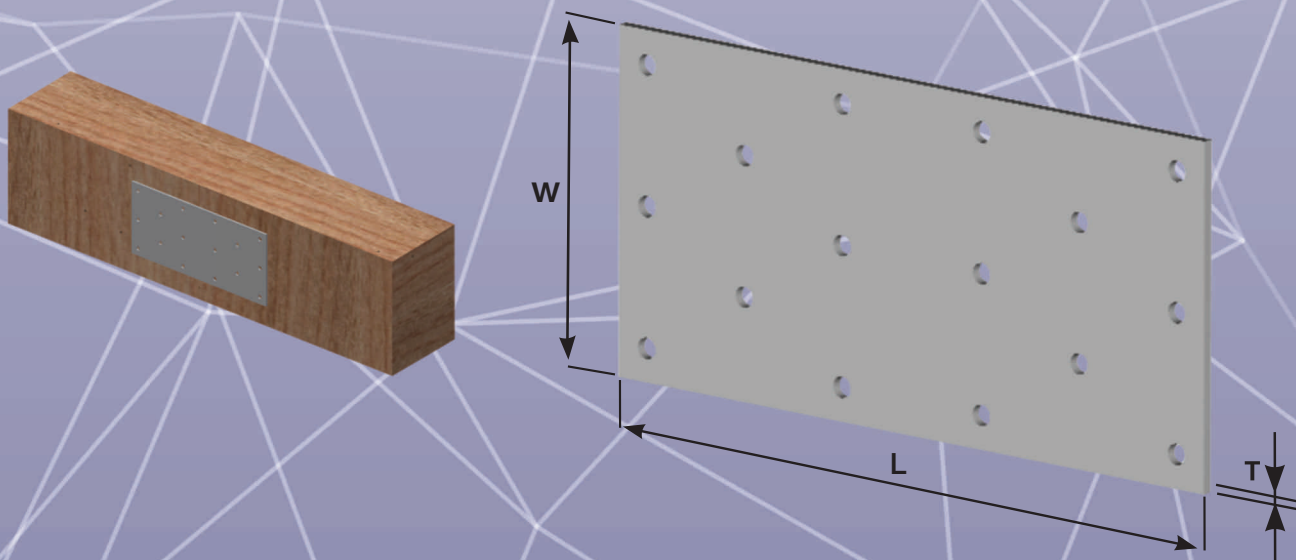

CONNECTOR BV/S 140 03 - 36

width $W = 30, 40, 50, 60, 70, 80, 90, 100, 110, 120, 130, 140$ mm
 length $L = 140$ mm
 material thickness $T = 1,5$ mm

ordering example :
 connector BV/S 140 03-36/W

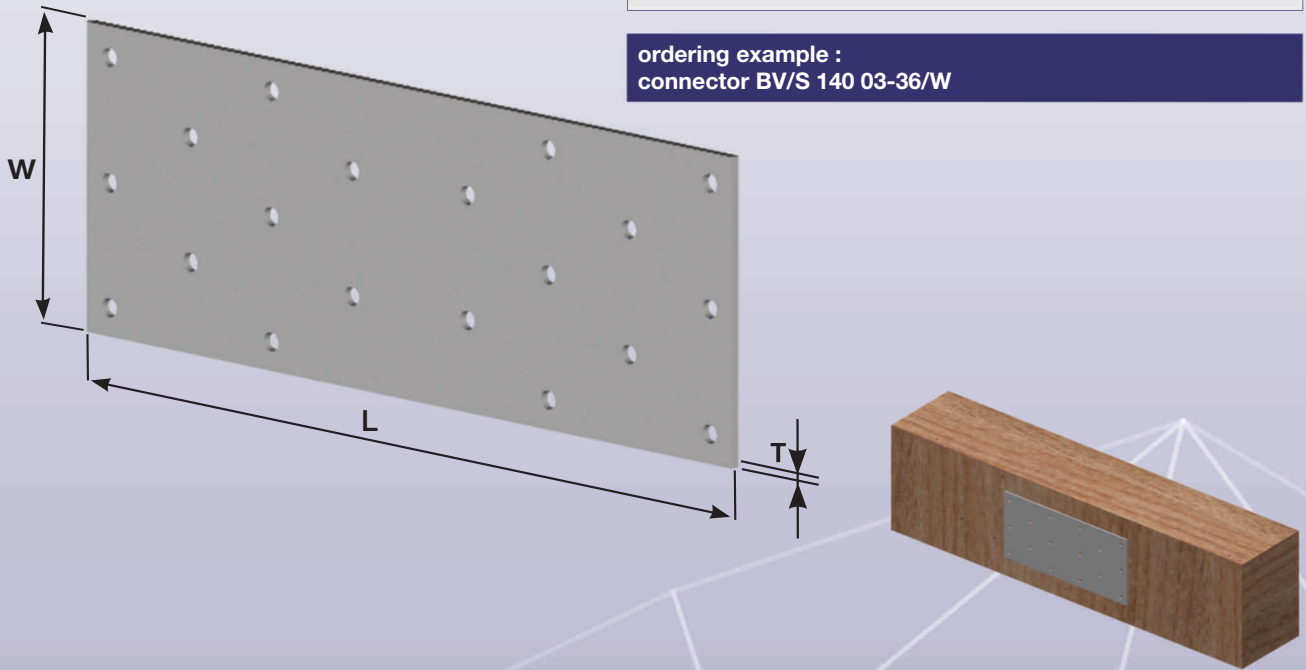

CAROB BV/R 03 - 40

Dimension	A	B	C	T
120	120	85	32	2
180	180	127	32	2
240	240	170	32	2

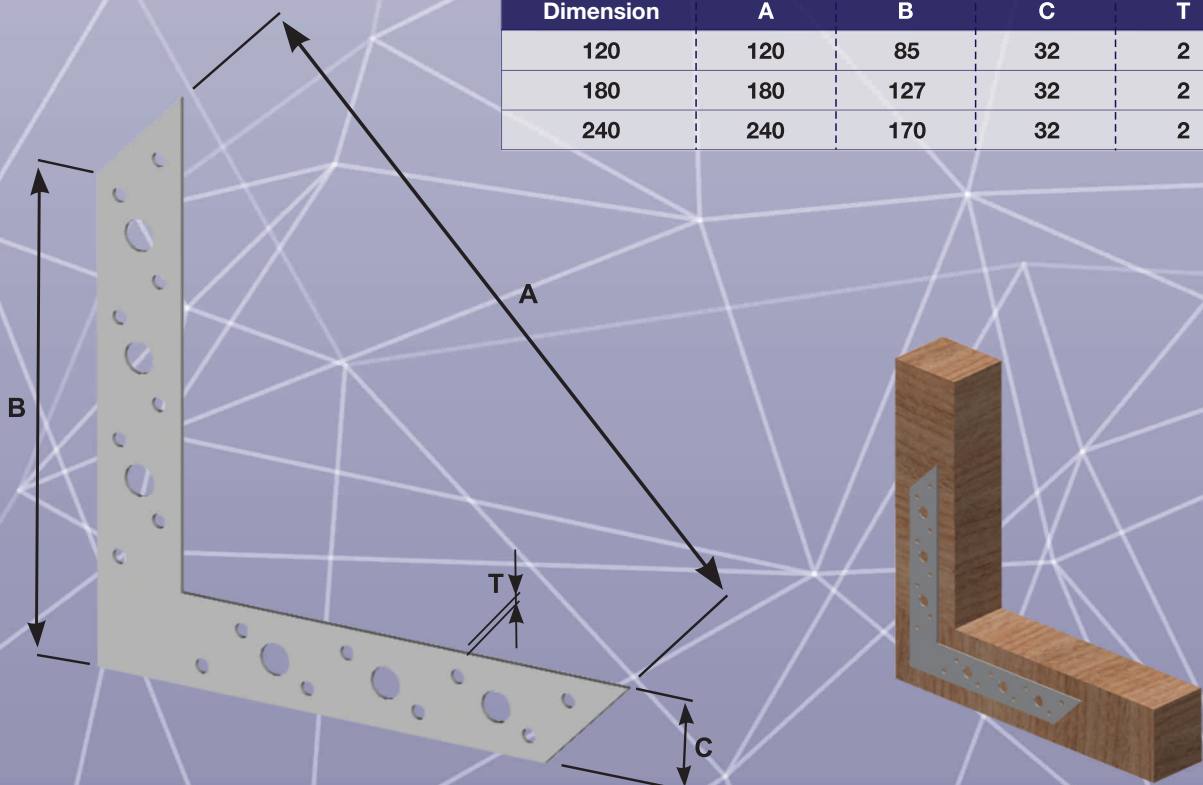

03 - 41 PIECEMEALER T BV/S

Dimension	A	B	C	D	T
	160	95	45	45	2

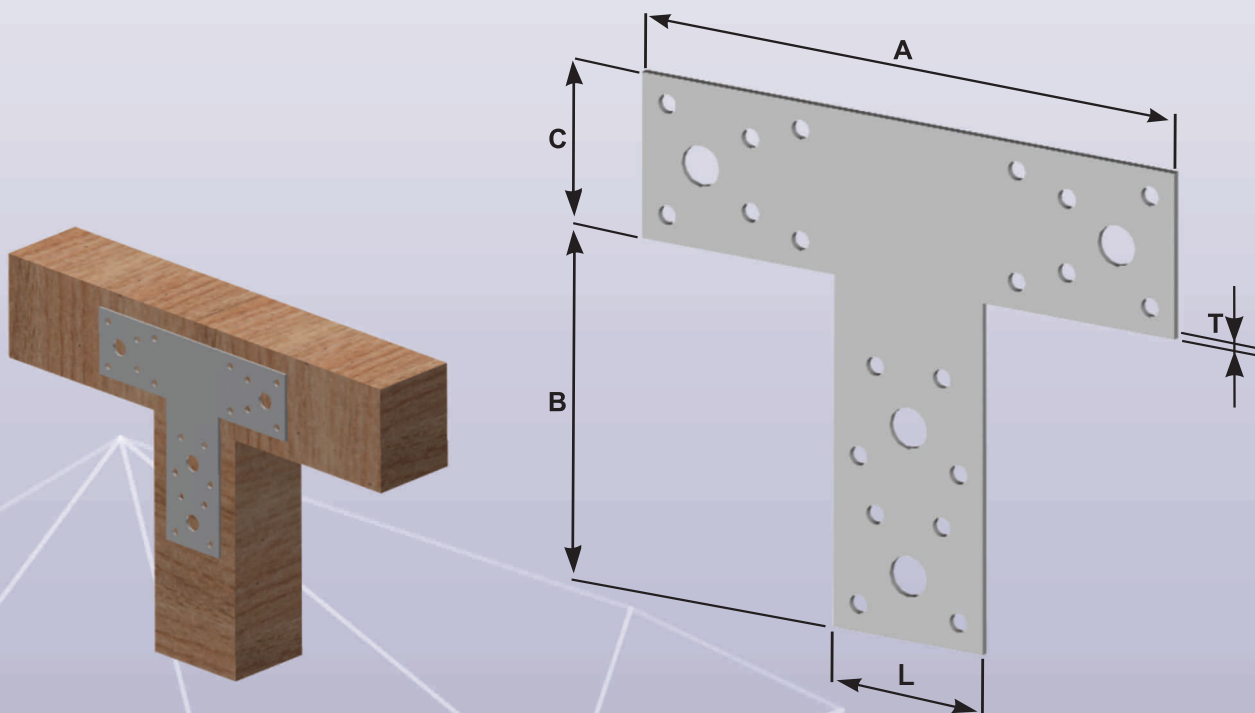

05 - 01 ANGLE BRACKET BV/Ú

width $W = 40, 60, 80, 120, 140, 160, 200, 240$ mm
 length $L, L1 = 40, 60, 80$ to 400 mm
 material thickness $T = 2$ mm

ordering example :
 angle bracket BV/Ú 05-01 $W \times L \times L1$

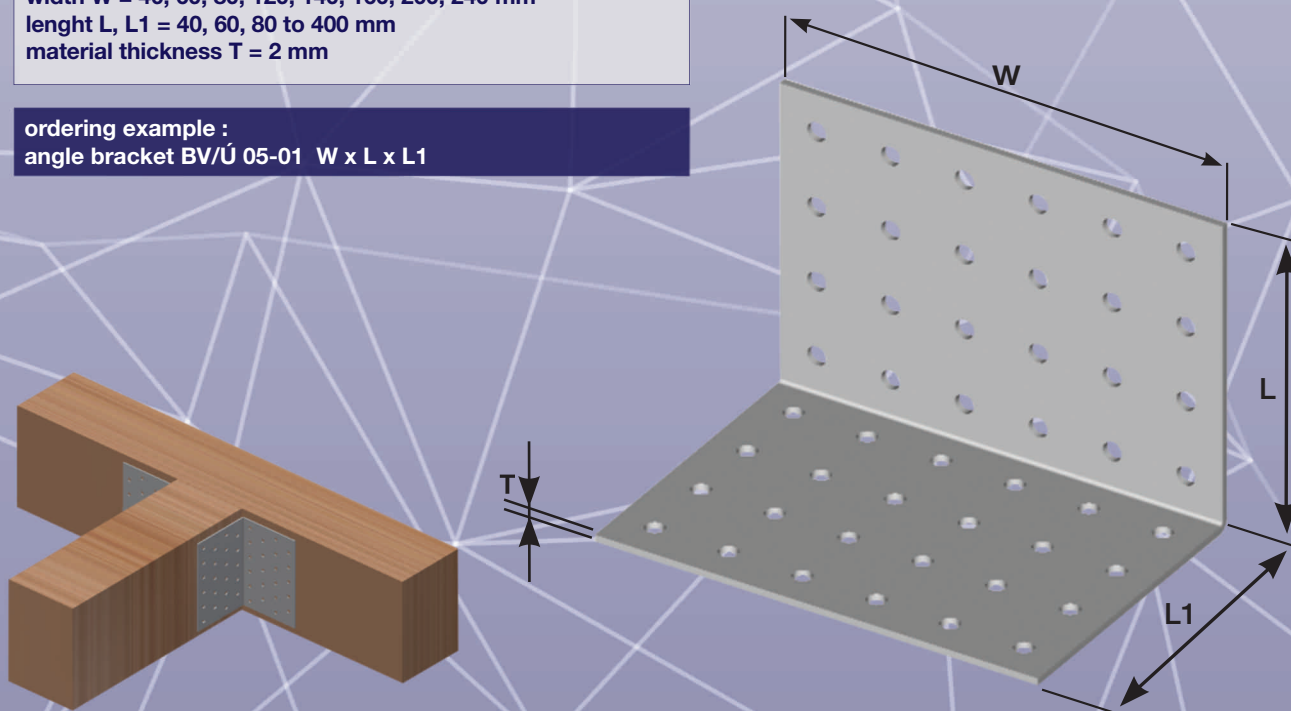

ANGLE BRACKET BV/ÚK 05 - 02

width W= 80, 120, 140, 160, 200, 240 mm
 length L, L1 = 40, 60, 80 to 400 mm
 material thickness T = 2 mm
 variation: left, right

ordering example :
 angle bracket BV/ÚK 05-02 W x W1 x T x L x L1

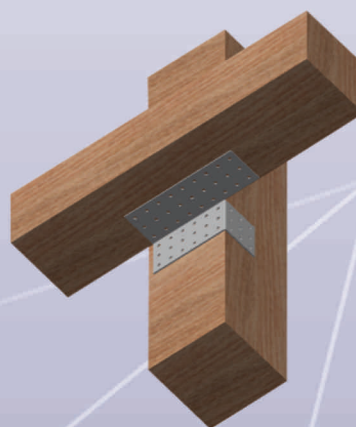
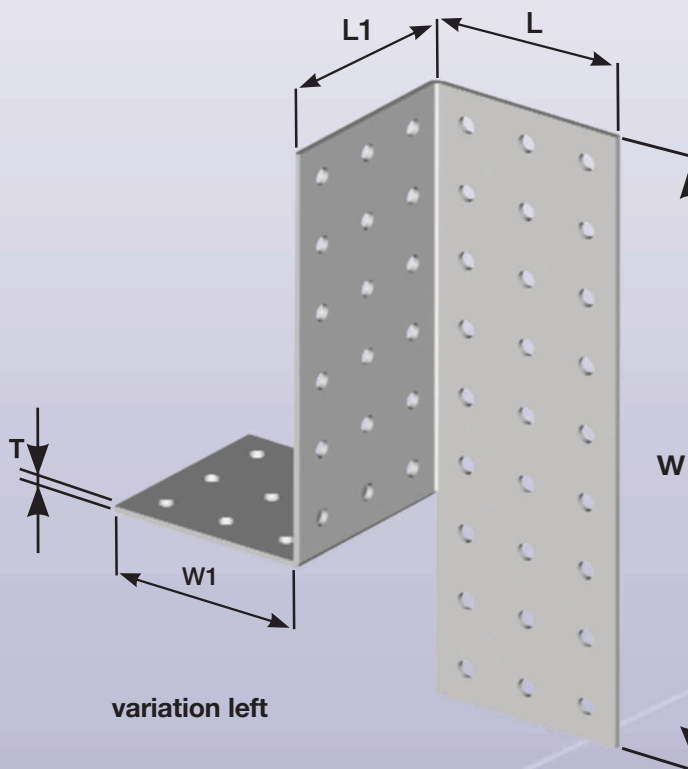

ANGLE BRACKET BV/ÚK 100 x 70 x 70 05 - 05

Dimension	W	L1	L	T
	100	70	70	2

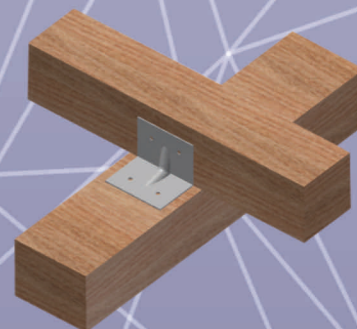
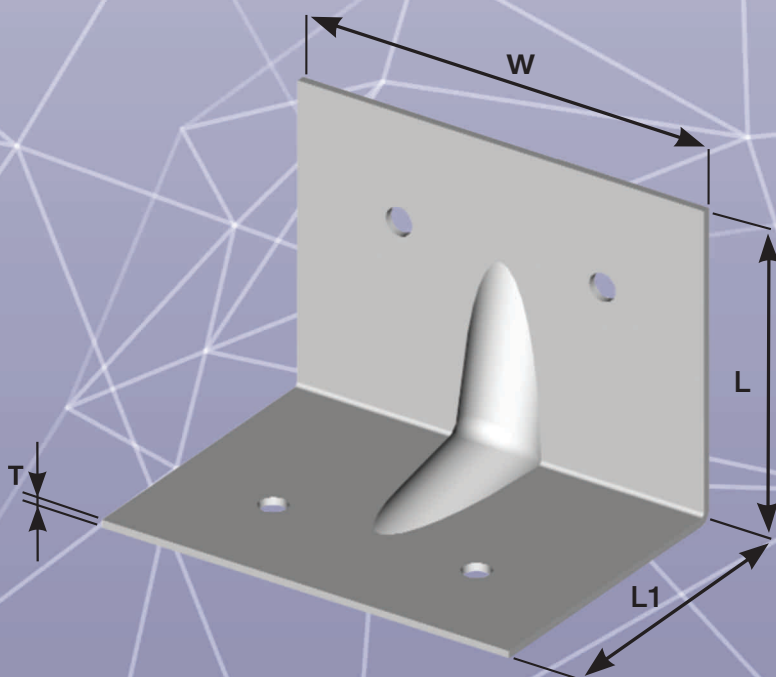

05 - 08 ANGLE BRACKET BV/Ú

width $W = 40, 60, 80, 100, 120, 140, 160, 200, 240, 280$ mm
length $L, L1 = 40, 60, 80$ to 400 mm
material thickness $T = 2$ mm

ordering example :
angle bracket BV/Ú 05-08 $W \times L \times L1$

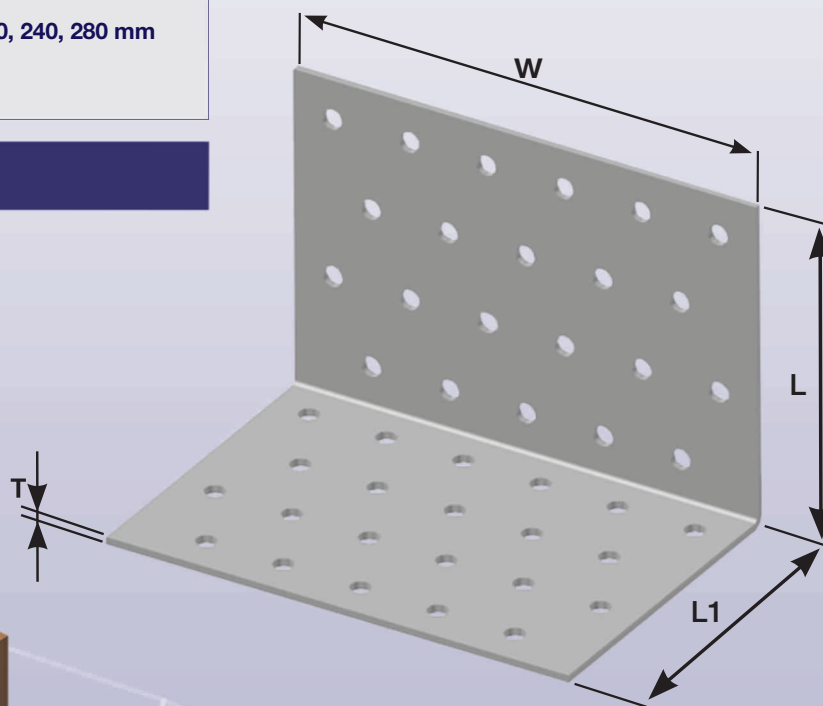
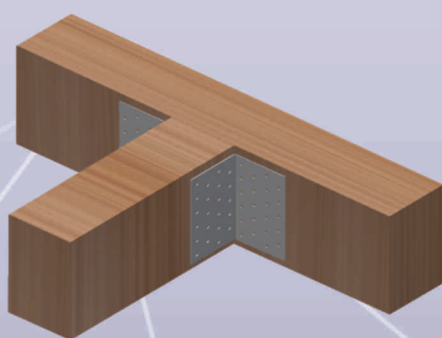

05 - 11 ANGLE BRACKET BV/Ú

width $W = 50, 60, 70, 80, 90$ mm
length $L, L1 = 70$ mm
material thickness $T = 2$ mm

ordering example :
angle bracket BV/Ú 05-11/W

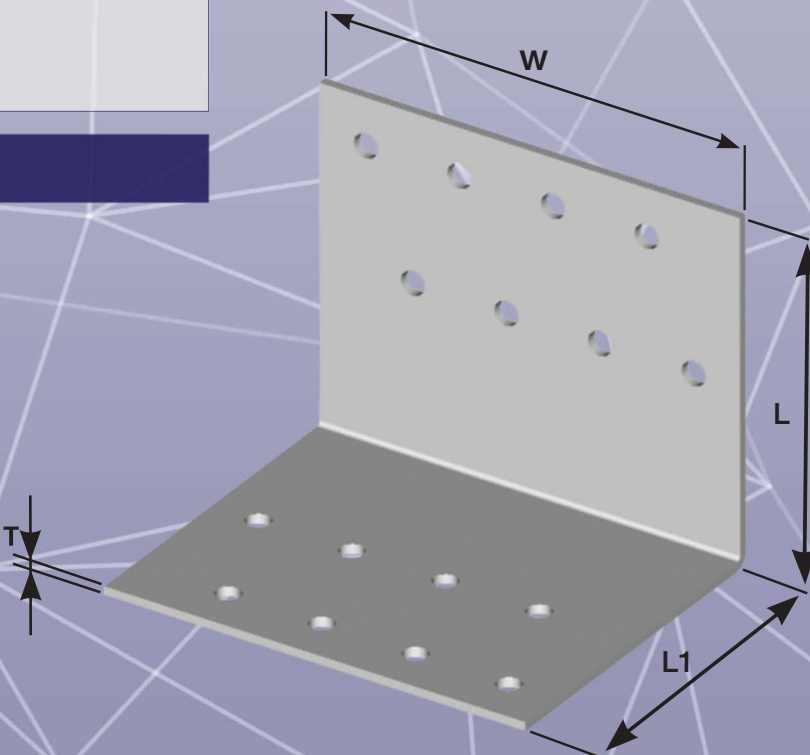
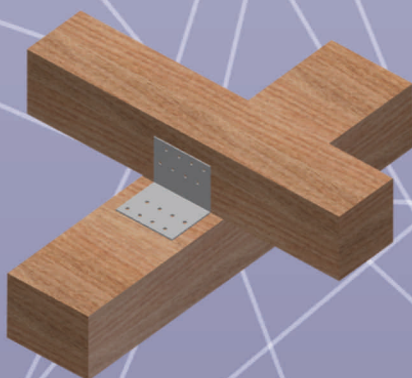

ANGLE BRACKET* BV/Ú 05 - 12

width $W = 50, 60, 70, 80, 90$ mm
length $L, L1 = 70$ mm
material thickness $T = 2$ mm

ordering example :
angle bracket with the reinforcement BV/Ú 05-12/W

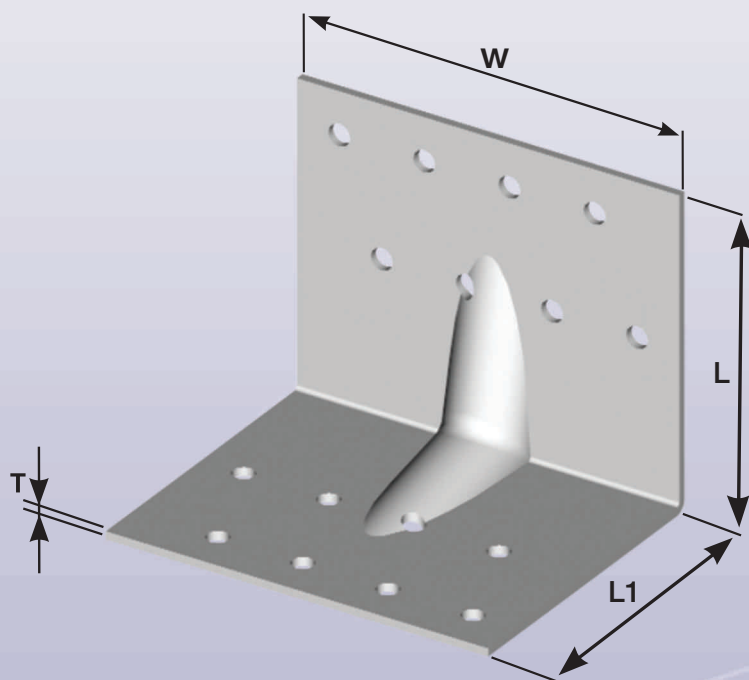

*with the reinforcement

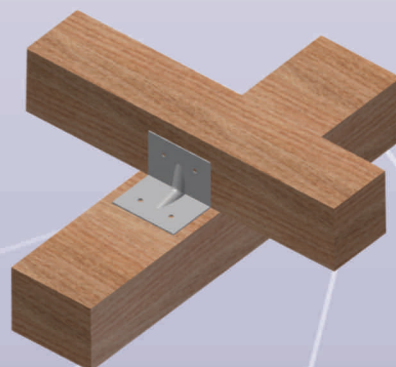

ANGLE BRACKET BV/Ú 05 - 16

width $W = 50, 60, 70, 80, 90$ mm
length $L, L1 = 70$ mm
material thickness $T = 2$ mm

ordering example :
angle bracket BV/Ú 05-16/W

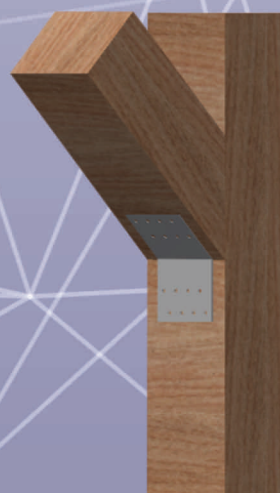
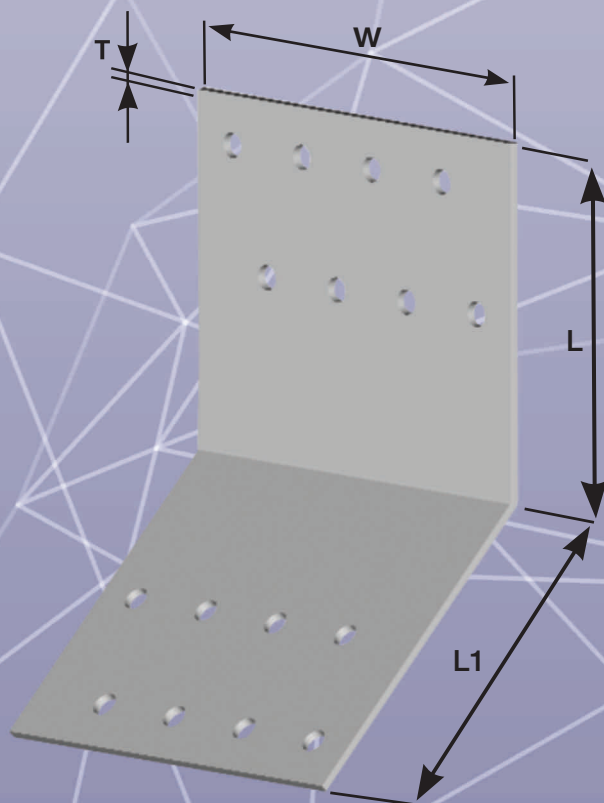

05 - 17/80

ANGLE BUCKET* BV/Ú

Dimension	W	L	L1	T
	80	108	63	2

*for the hip roof

variation: left,right

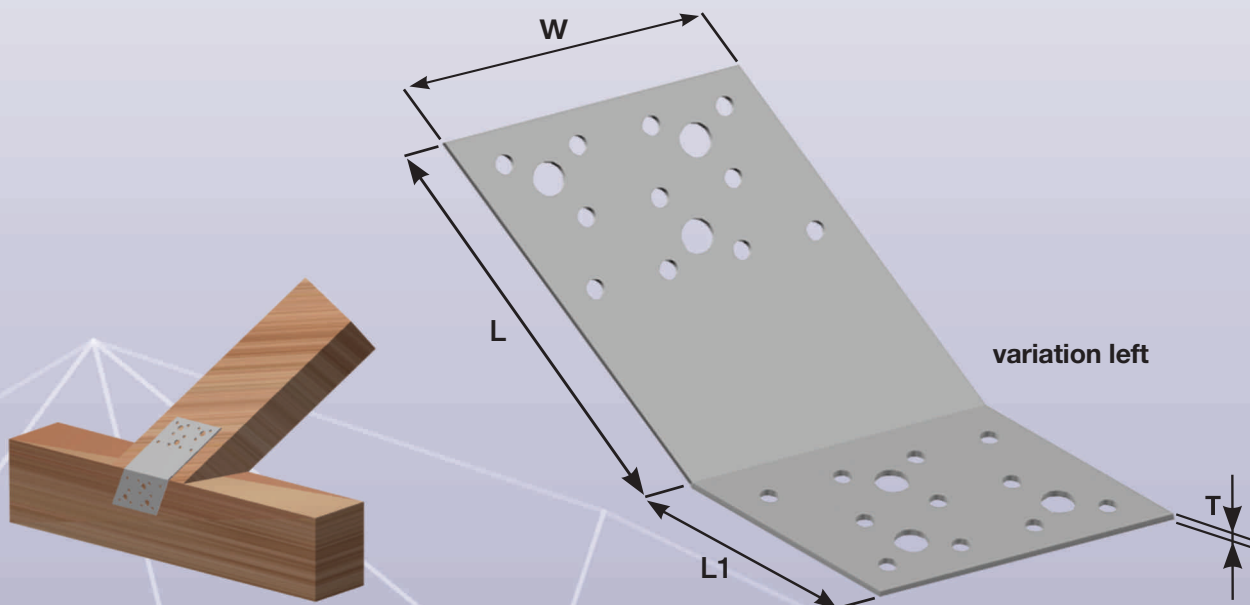

05 - 18/120

ANGLE BUCKET* BV/Ú

Dimension	W	L	L1	T
	120	108	63	2

*for the hip roof

variation: left,right

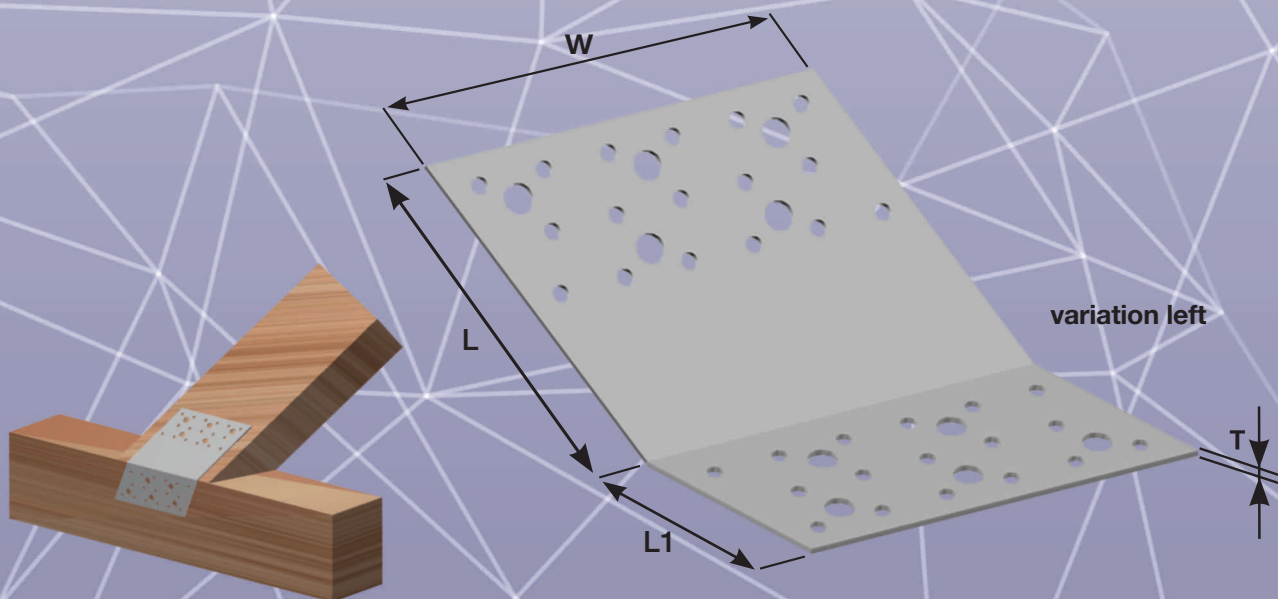

ANGLE BUCKET* BV/Ú

05 - 19/80

*for the hip roof

Dimension	W	L	L1	T
	80	86	63	2

variation: left, right

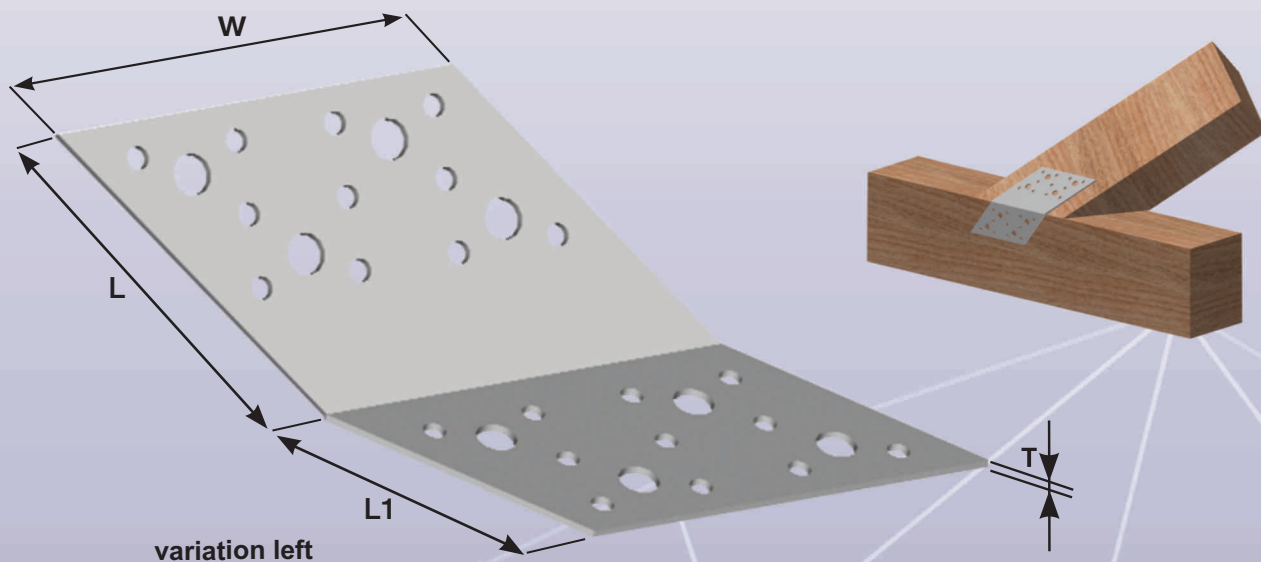

ANGLE BUCKET* BV/Ú

05 - 20/120

*for the hip roof

Dimension	W	L	L1	T
	120	86	63	2

variation: left, right

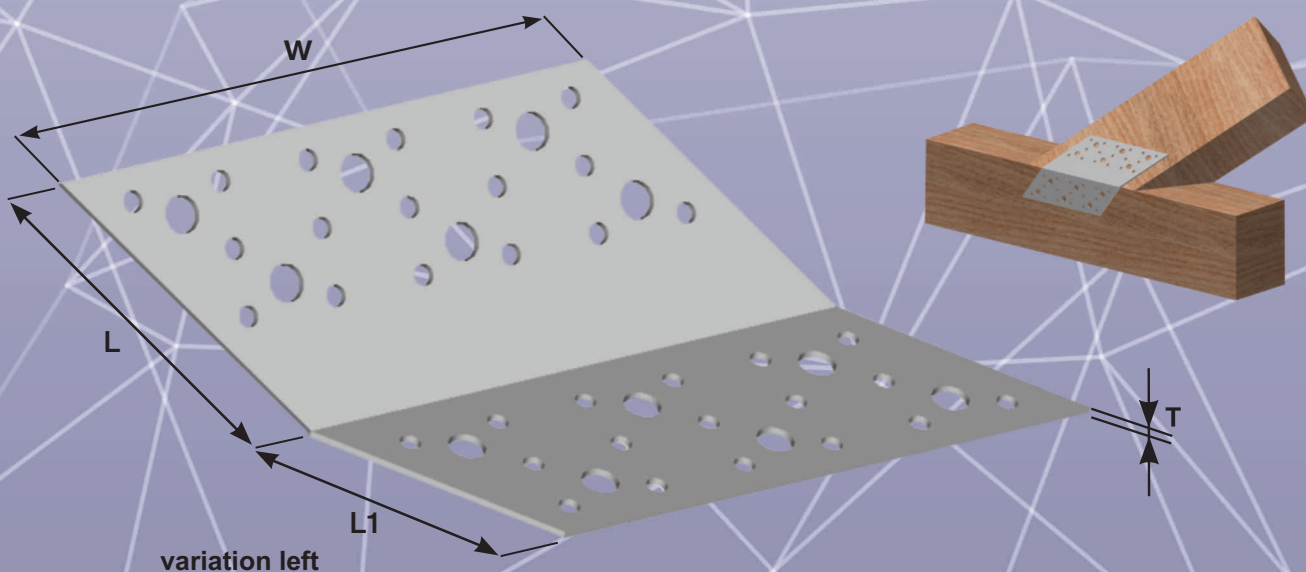

05 - 21/V ANGLE BRACKET* BV/Ú 55 x 70 x 70

Dimension	W	L	L1	T
	55	72	72	2

*with stiffener

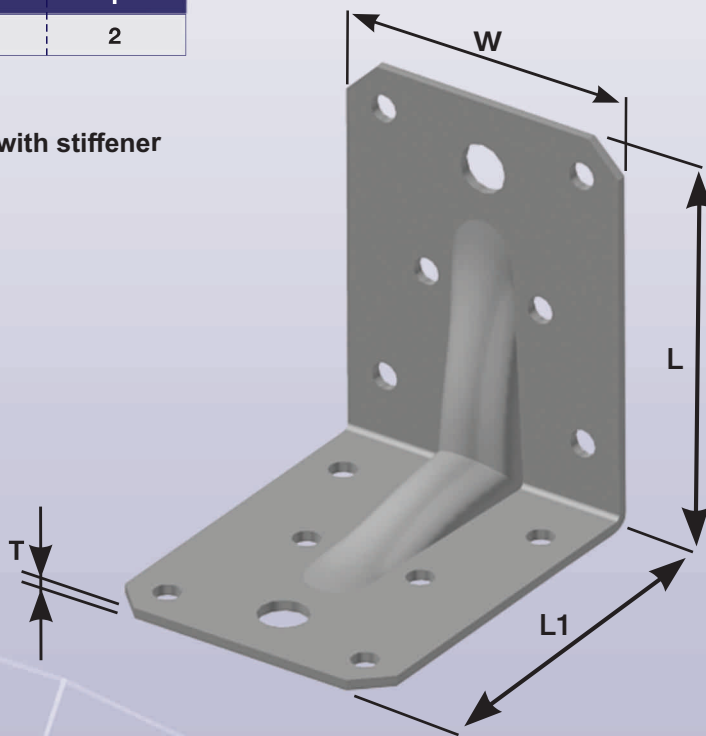
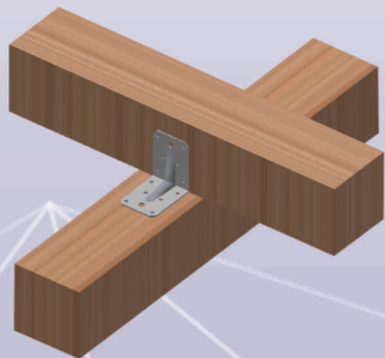

05 - 21/BV ANGLE BRACKET* BV/Ú 55 x 70x 70

Dimension	W	L	L1	T
	55	72	72	2

*without stiffener

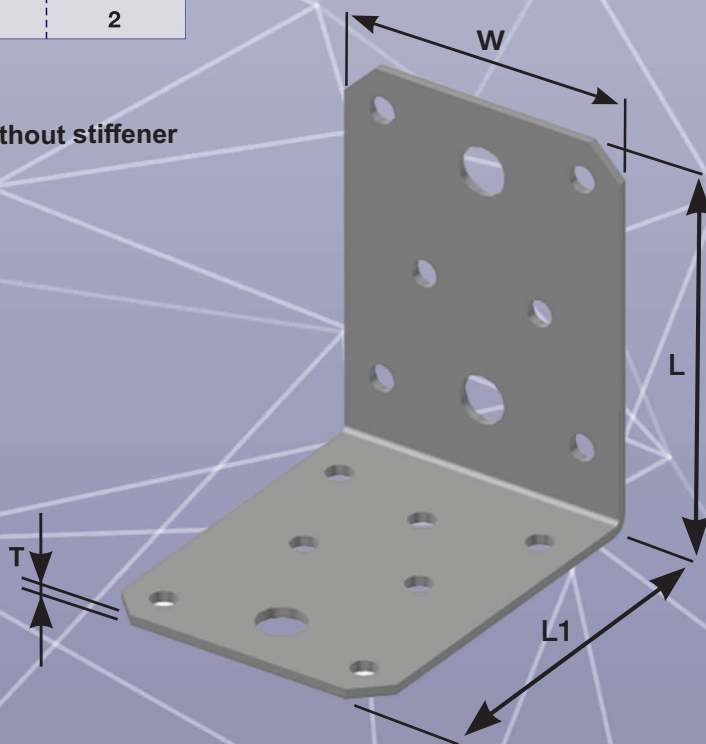
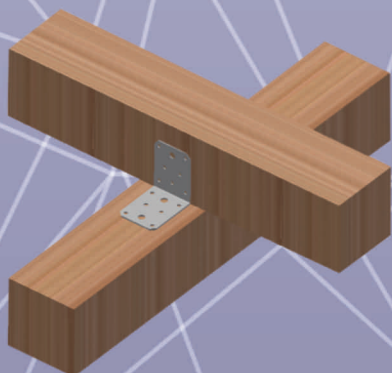

ANGLE BRACKET* BV/Ú 65 x 90 x 90

05 - 22/V

Dimension	W	L	L1	T
	65	92,5	92,5	2,5

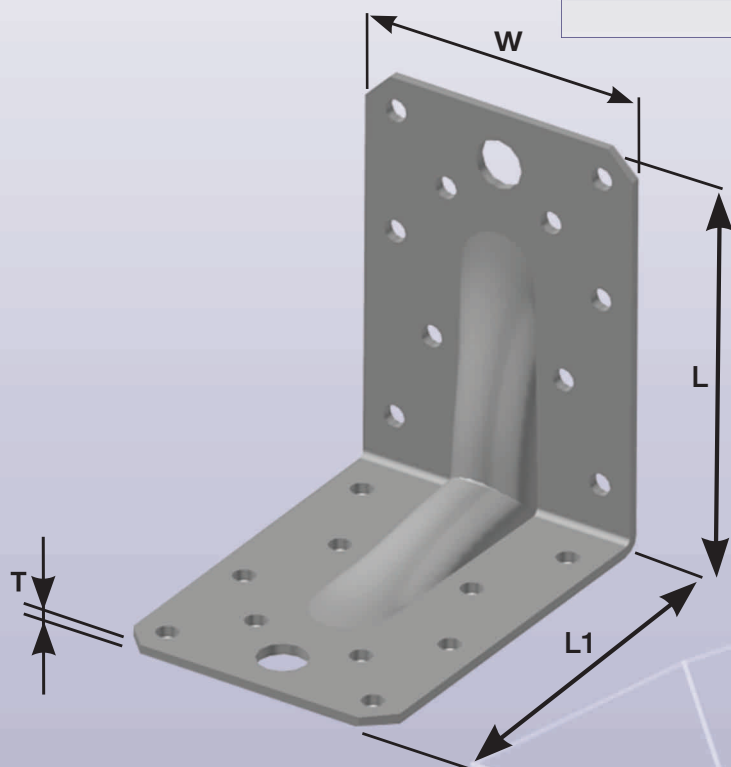

*with stiffener

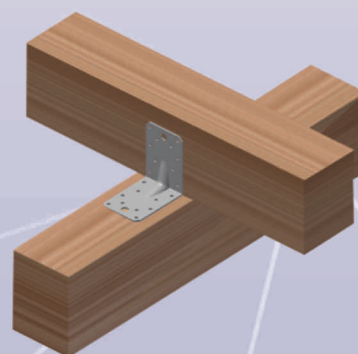

ANGLE BRACKET* BV/Ú 65 x 90 x 90

05 - 22/BV

Dimension	W	L	L1	T
	65	92,5	92,5	2,5

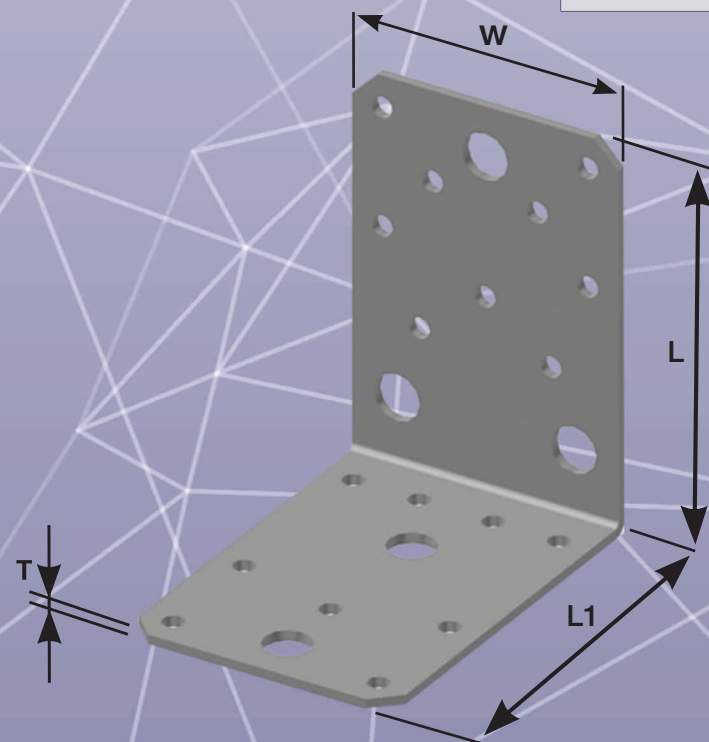

*without stiffener

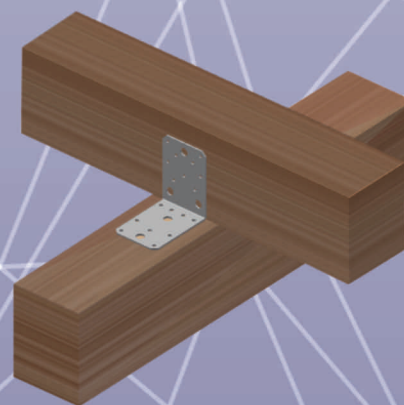

05 - 23/V ANGLE BRACKET* BV/Ú 90 x 105 x 105

Dimension	W	L	L1	T
	90	105	105	3

*with stiffener

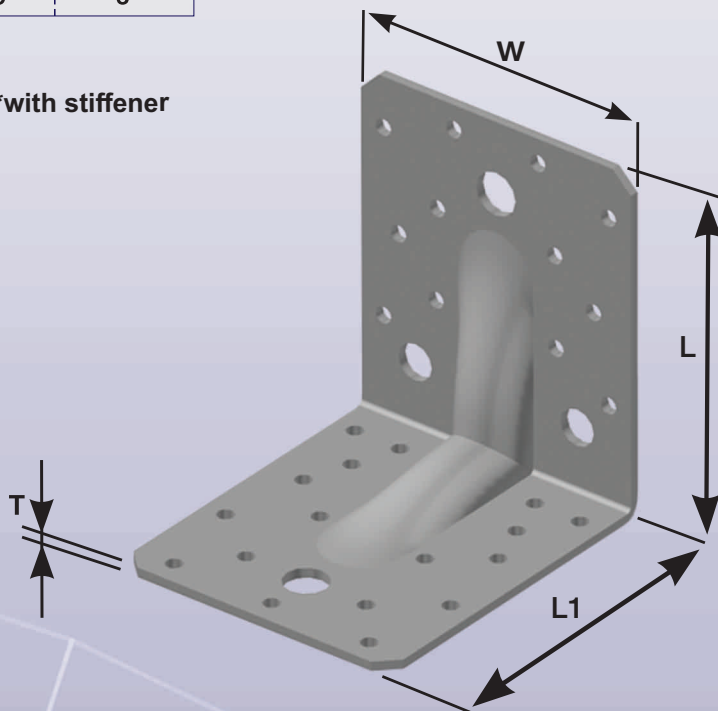
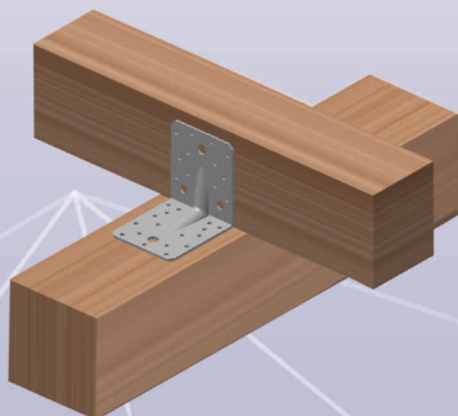

05 - 23/BV ANGLE BRACKET* BV/Ú 90 x 105 x 105

Dimension	W	L	L1	T
	90	105	105	3

*without stiffener

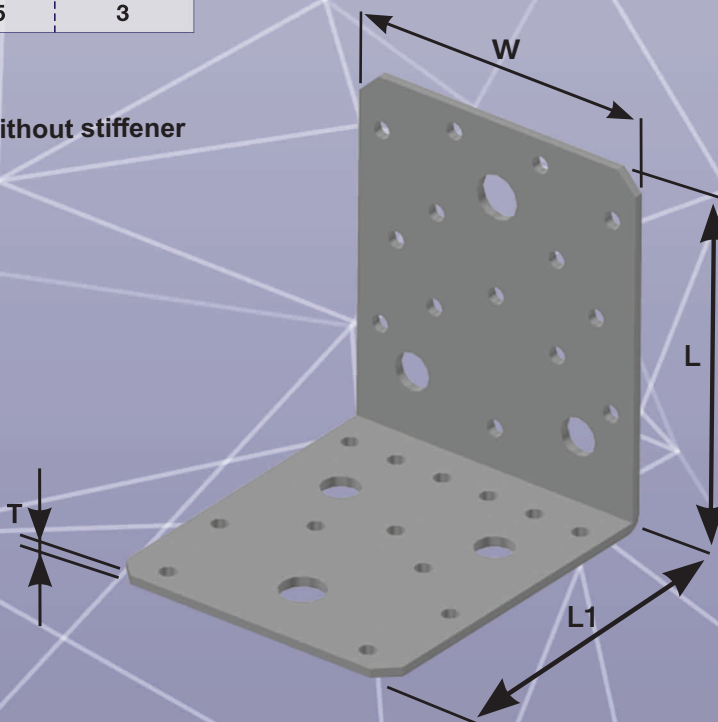
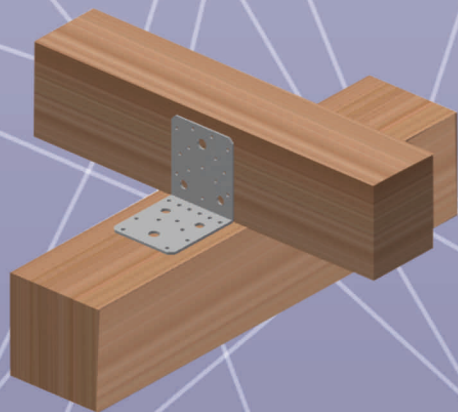

ANGLE BRACKET* 90 x 105 x 105

05 - 23/O

Dimension	W	L	L1	T
	90	105	105	3

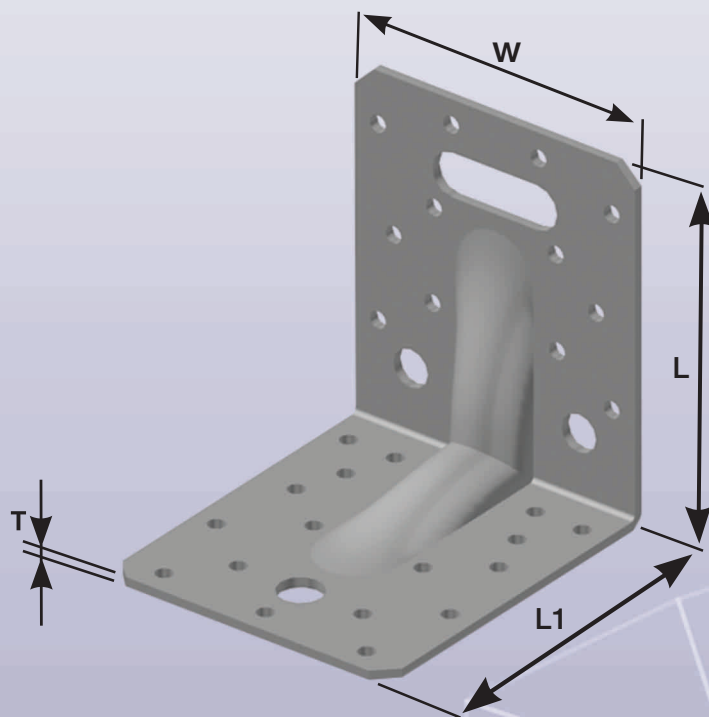

*with oval 40 x 13

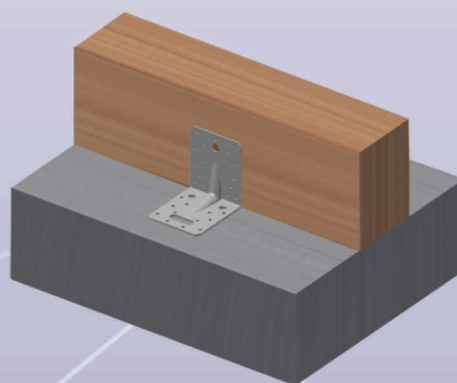

ANGLE BRACKET* 35 x 50 x 50

05 - 23/O

Dimension	W	L	L1	T
	35	50	50	2

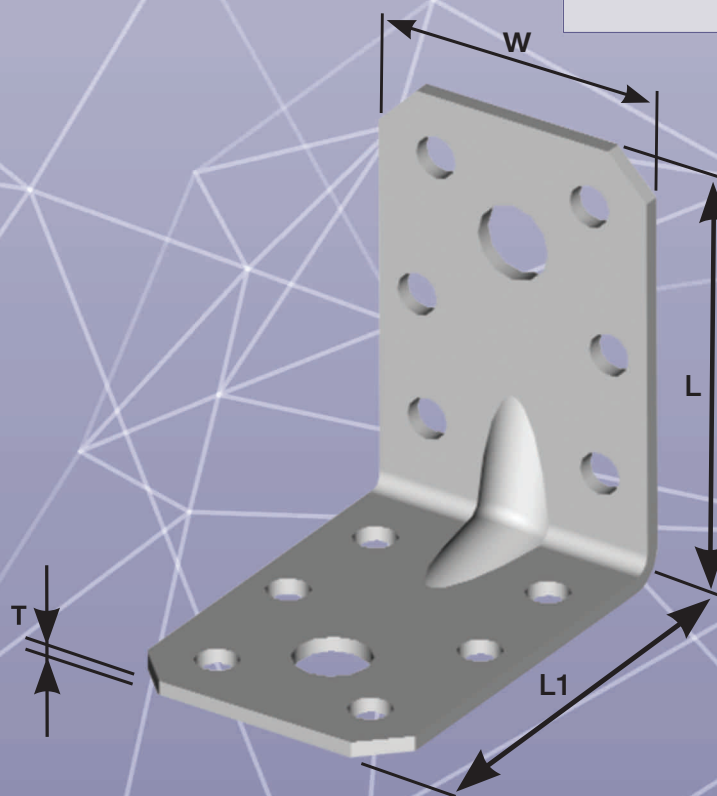

*with stiffener

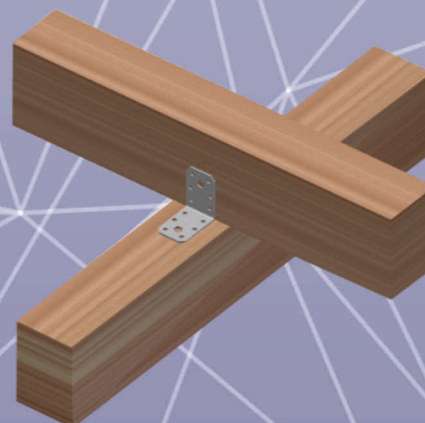

05 - 24/BV ANGLE BRACKET* BV/Ú 35 x 50 x 50

Dimension	W	L	L1	T
	35	50	50	2

*with stiffener

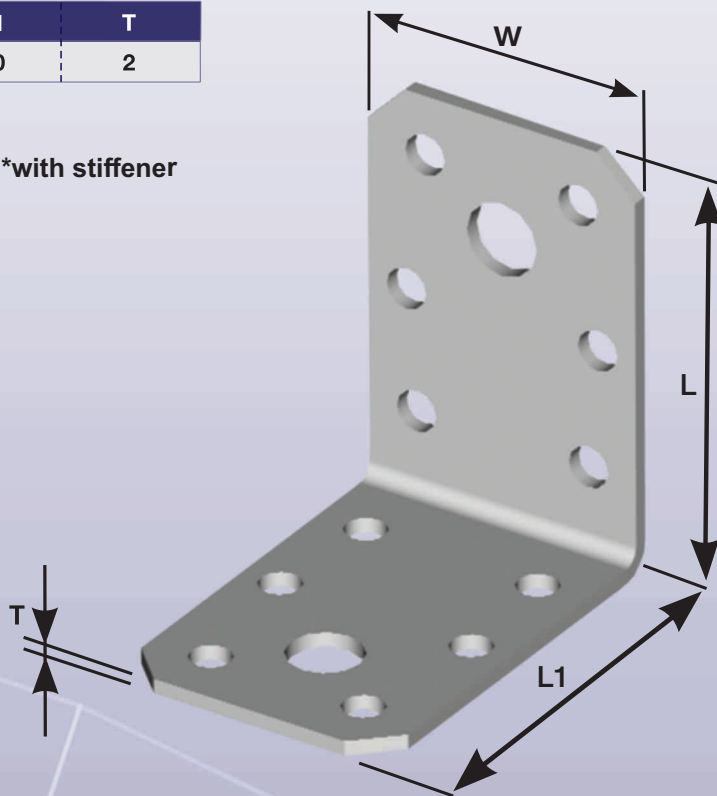
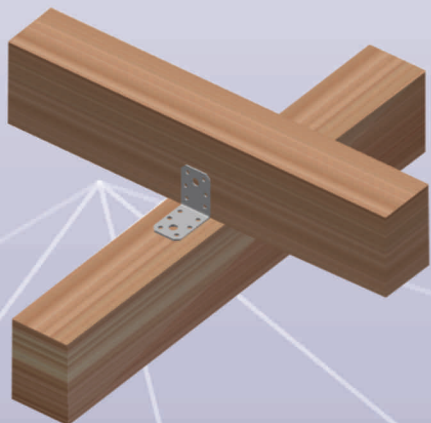

05 - 25/V ANGLE BRACKET* BV/Ú 45 x 60 x 60

Dimension	W	L	L1	T
	45	60	60	2

*without stiffener

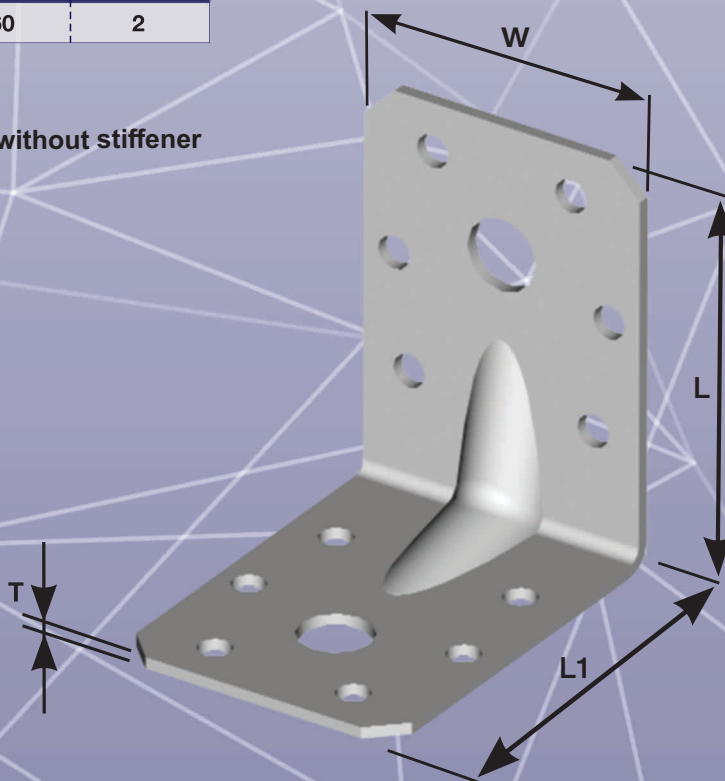
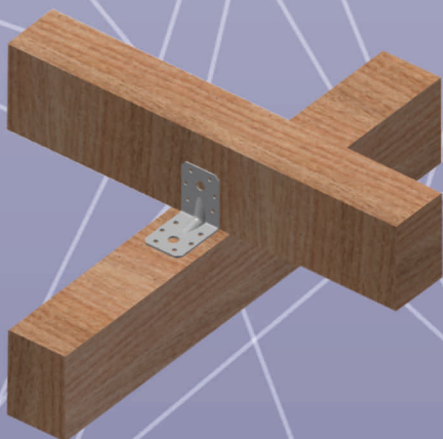

ANGLE BRACKET* BV/Ú 45 x 60 x 60 05 - 25/BV

Dimension	W	L	L1	T
	45	60	60	2

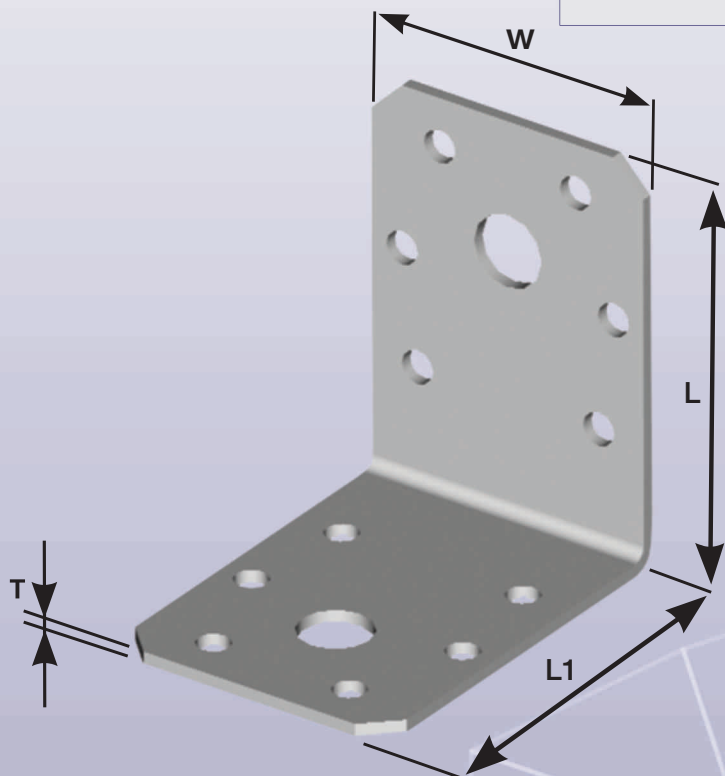

*without stiffener

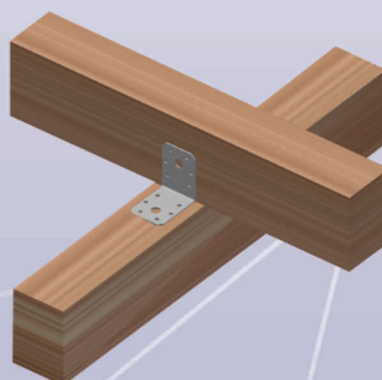

ANGLE BRACKET BV/Ú 05 - 27

Dimension	W	L	T
70	40	70	3
110	40	110	3

ordering example :
angle bracket BV/Ú 05 - 27/L

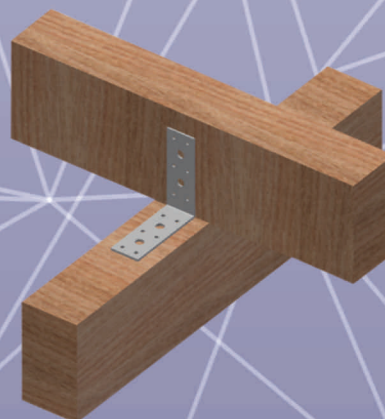
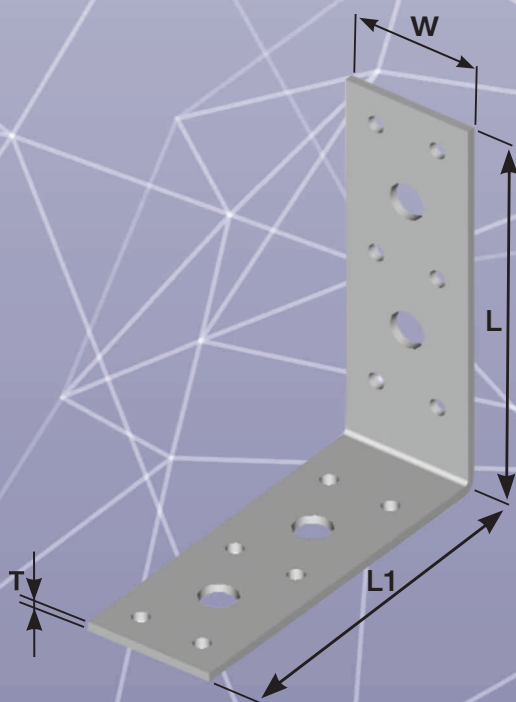

05 - 31 ANGLE BRACKET BV/Ú 40 x 40

length D = 150, 170, 210, 250, 290, 330 mm
length L, L1 = 40 mm
material thickness T = 2 mm
variation: left, right

ordering example :
angle bracket BV/Ú 05-31/D - left, right

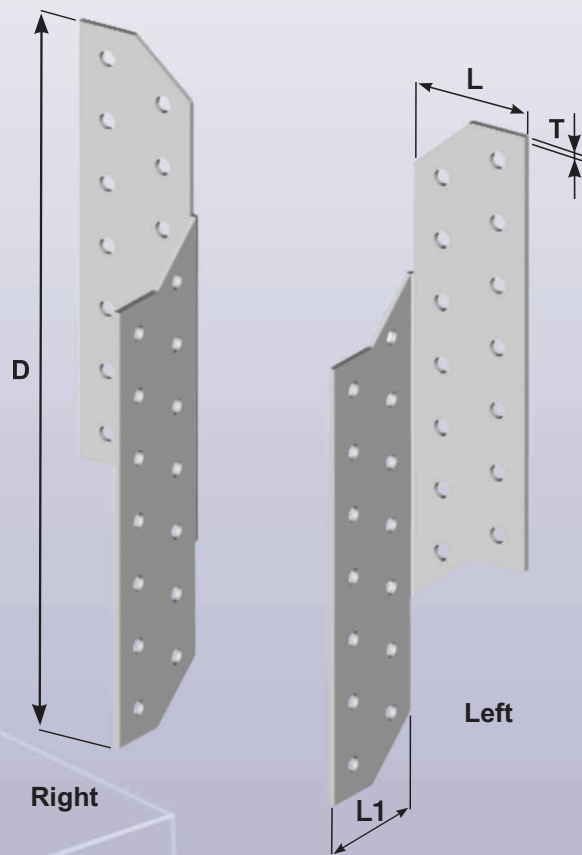
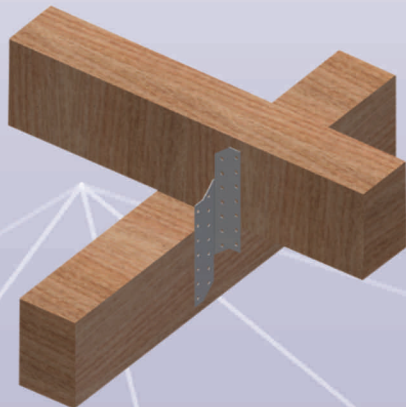

05 - 32 ANGLE BRACKET BV/Ú 35 x 35

length D = 150, 170, 210 mm
length L, L1 = 35 mm
material thickness T = 1,5 mm
variation: left, right

ordering example :
angle bracket BV/Ú 05-32/D - left, right

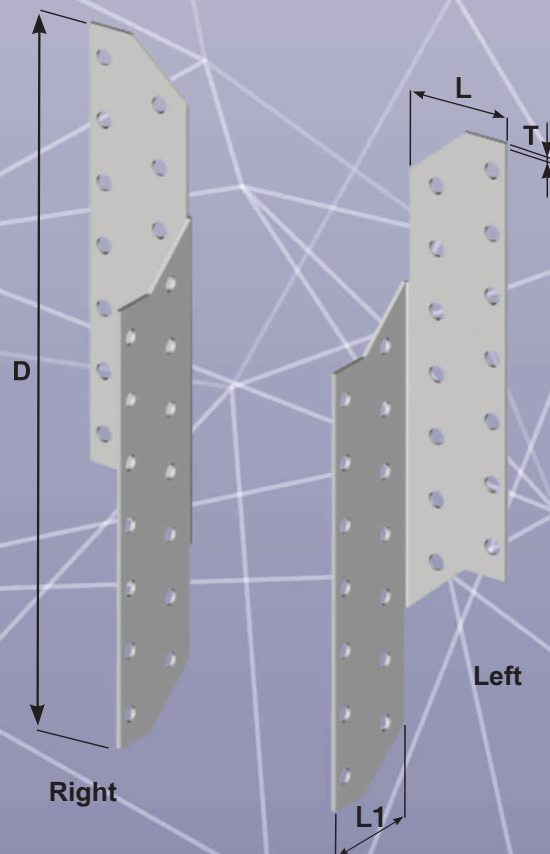
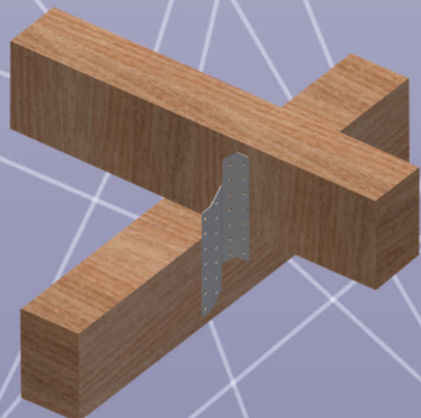

STILT BV/P 100

05 - 40

Dimension	A	B	C	T
	100	100	65	2

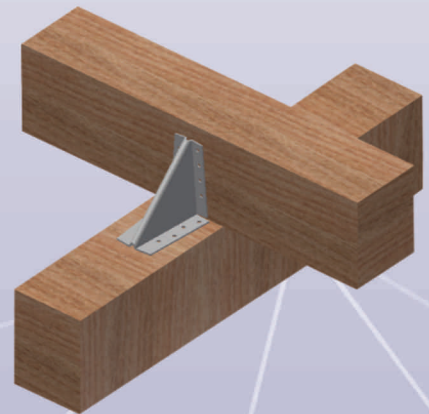
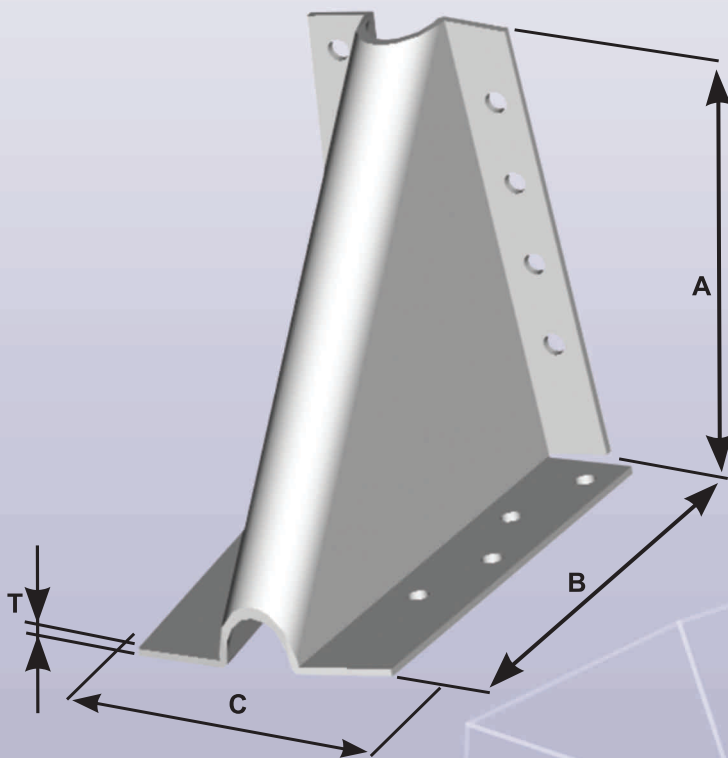

STILT BV/P 120

05 - 41

Dimension	A	B	C	T
	110	110	80	2

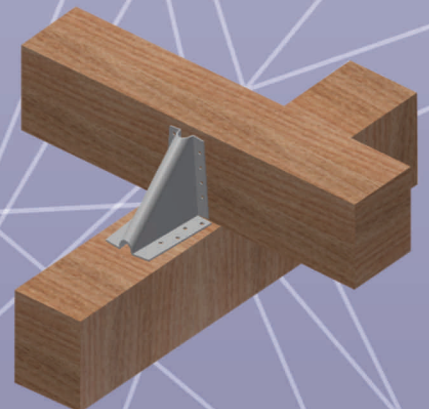
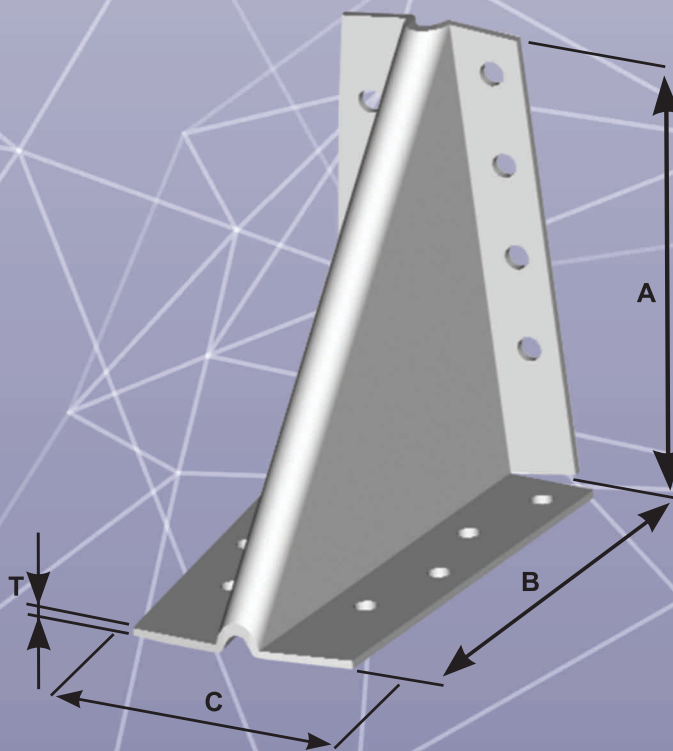

05 - 42 STILT BV/P 160

Dimension	A	B	C	T
	150	150	95	2

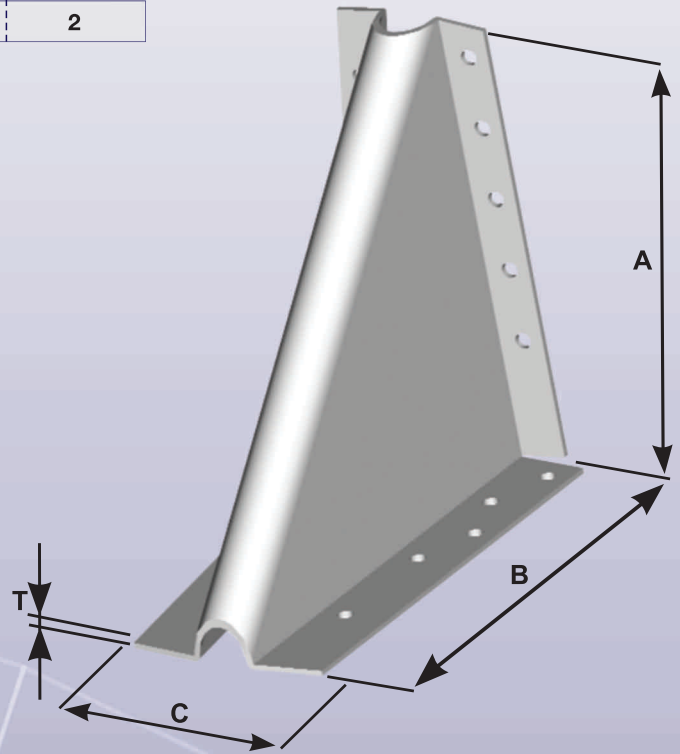
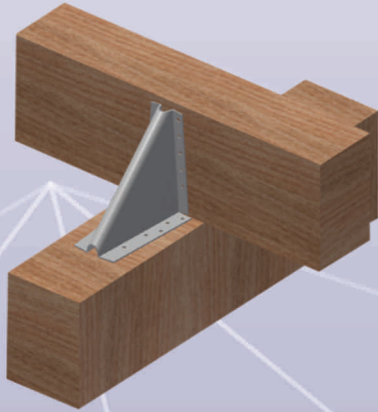

05 - 43 STILT BV/P 200

Dimension	A	B	C	T
	190	190	100	2

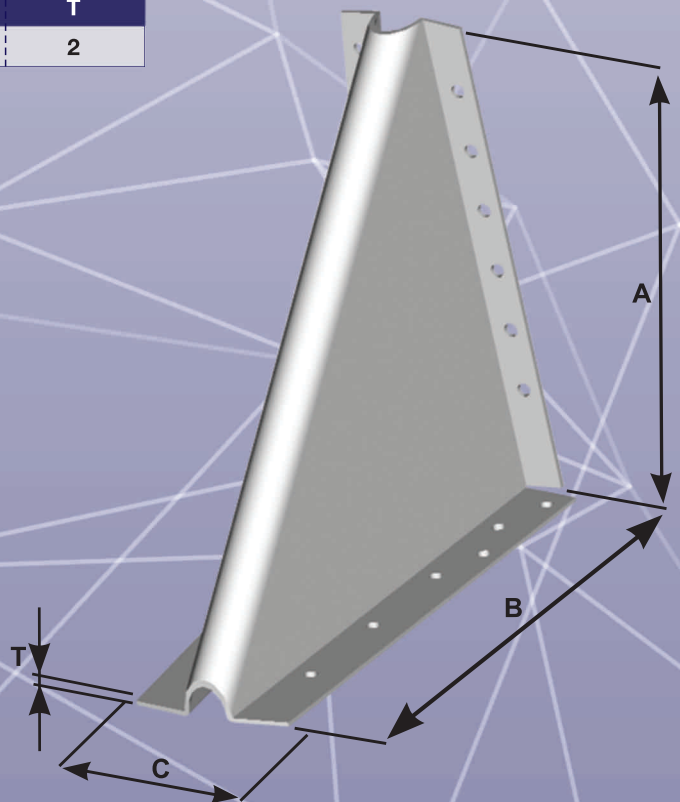
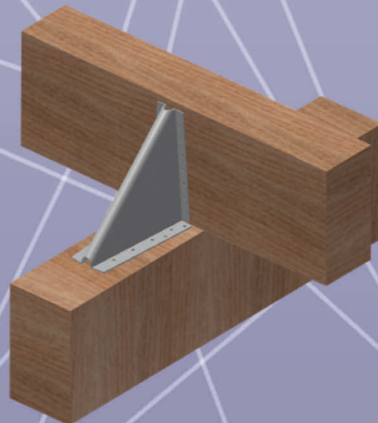

RIBBAND CONNECTOR BV/ST 05 - 50

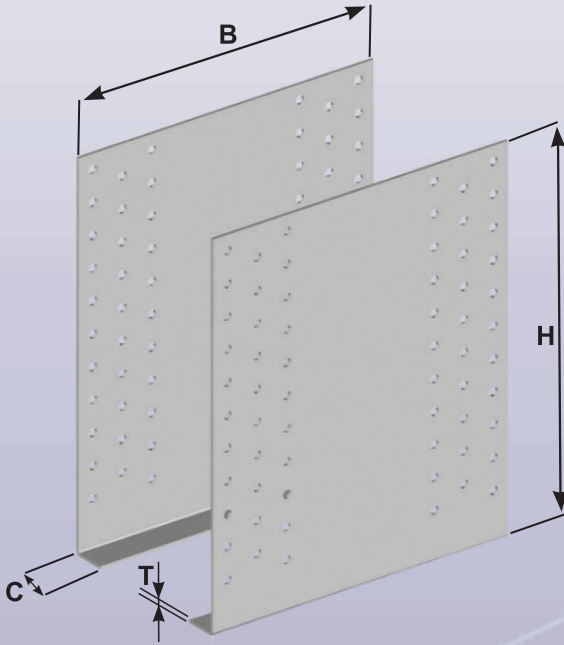

Dimension	H	B	C	T
80	80	200	20	2
100	100	200	20	2
120	120	200	20	2
140	140	200	20	2
160	160	200	20	2
180	180	200	20	2
200	200	200	20	2
220	220	200	20	2
240	240	200	20	2

ordering example :
ribband connector BV/ST 05-50/H

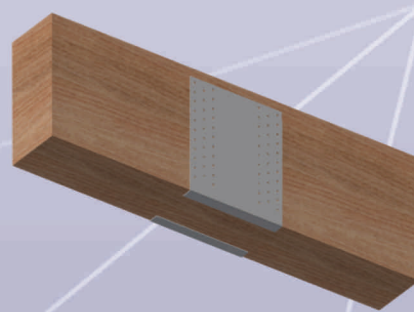

RIBBAND CONNECTOR BV/ST 05 - 51

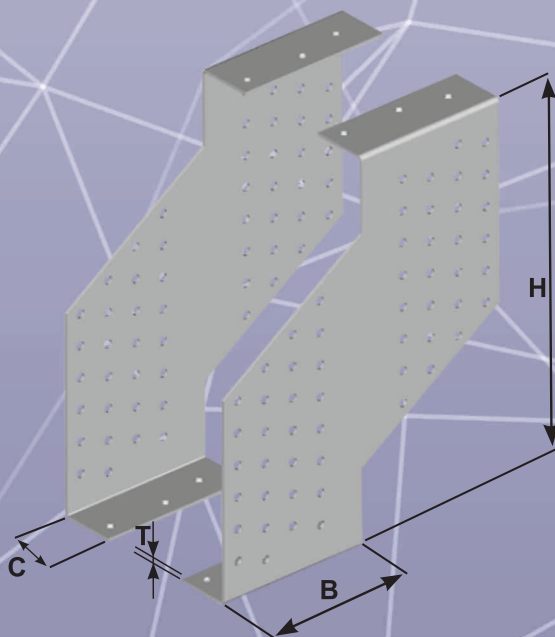

Dimension	H	B	C	T
100	100	100	27	2
120	120	100	27	2
140	140	100	30	2
150	150	100	30	2
160	160	100	30	2
180	180	100	34	2
200	200	100	34	2
220	220	100	34	2
240	240	100	34	2

ordering example :
ribband connector BV/ST 05-51/H

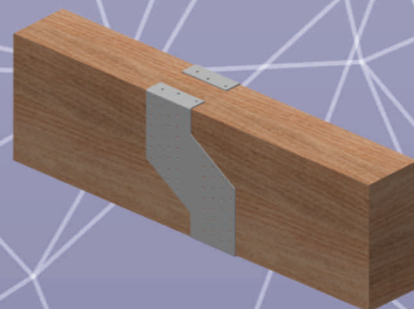

05 - 80 ANGLE BV/Ú

width $W = 30, 40, 50, 60, 70, 80, 90, 100, 110, 120, 130, 140$ mm
length $L, L1 = 35$ mm
material thickness $T = 1,5$ mm

ordering example :
angle BV/Ú 05-80/W

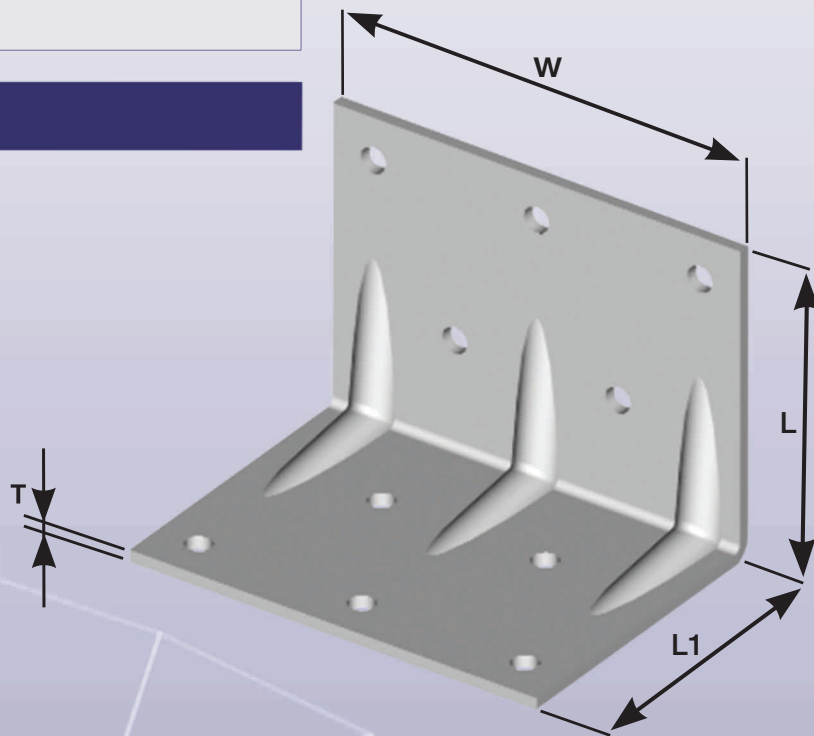
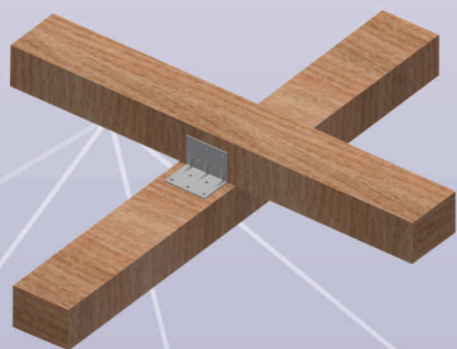

05 - 81 ANGLE BV/Ú

width $W = 30, 40, 50, 60, 70, 80, 90, 100, 110, 120, 130, 140$ mm
length $L, L1 = 53$ mm
material thickness $T = 1,5$ mm

ordering example :
angle BV/Ú 05-81/W

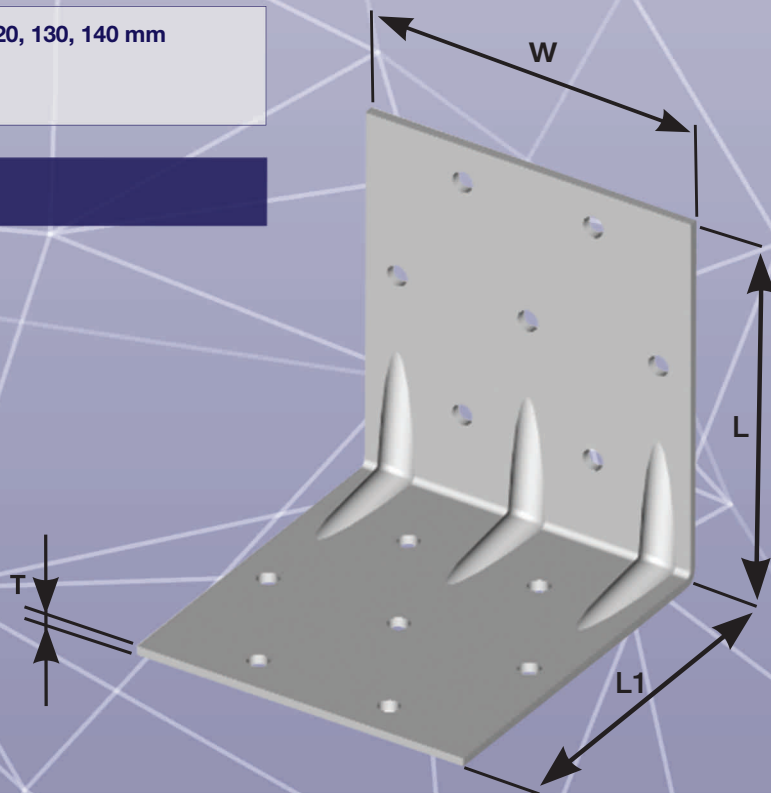
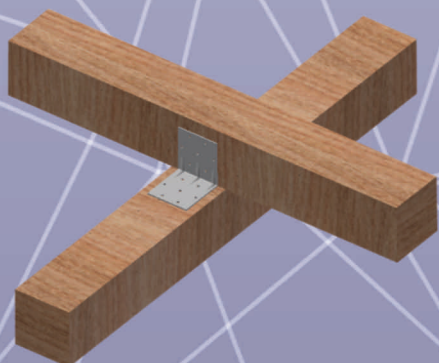

ANGLE BV/Ú 05 - 82

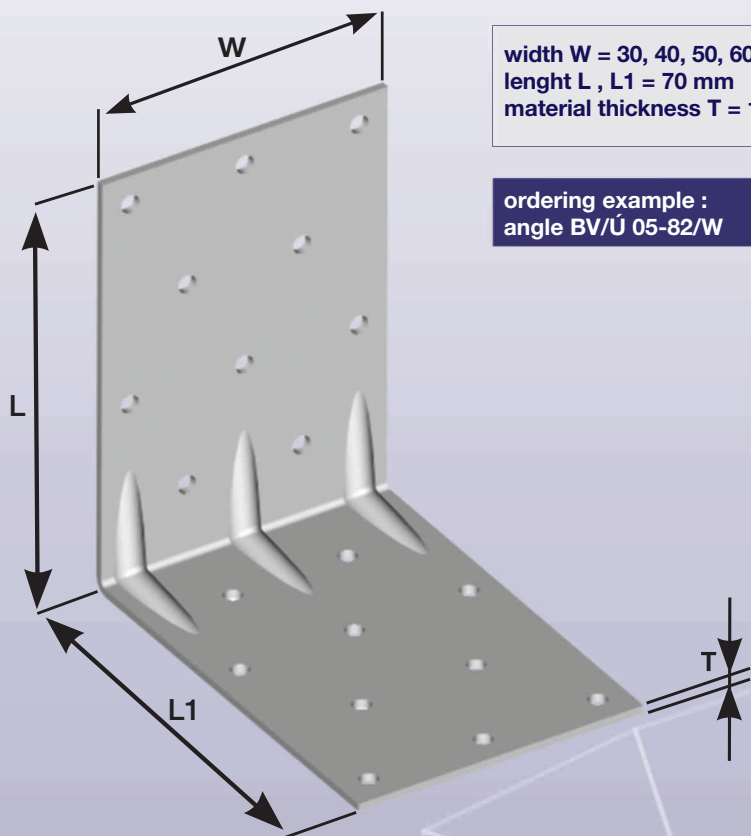

width $W = 30, 40, 50, 60, 70, 80, 90, 100, 110, 120, 130, 140$ mm
length $L, L1 = 70$ mm
material thickness $T = 1,5$ mm

ordering example :
angle BV/Ú 05-82/W

BRACKING STRAPS BV/ZP 10 - 01



width $W = 40$ mm
length $L = \text{max. } 50$ m
material thickness $T = 2$ mm

ordering example :
bracking straps BV/ZP 10-01/L

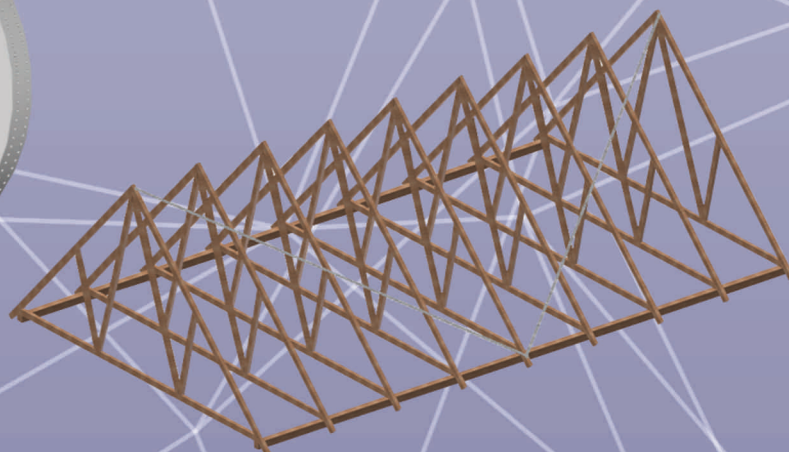

10 - 02 BRACKING STRAPS BV/ZP

width $W = 40$ mm
length $L = \text{max. } 50$ m
material thickness $T = 2$ mm

ordering example :
bracking straps BV/ZP 10-02/L

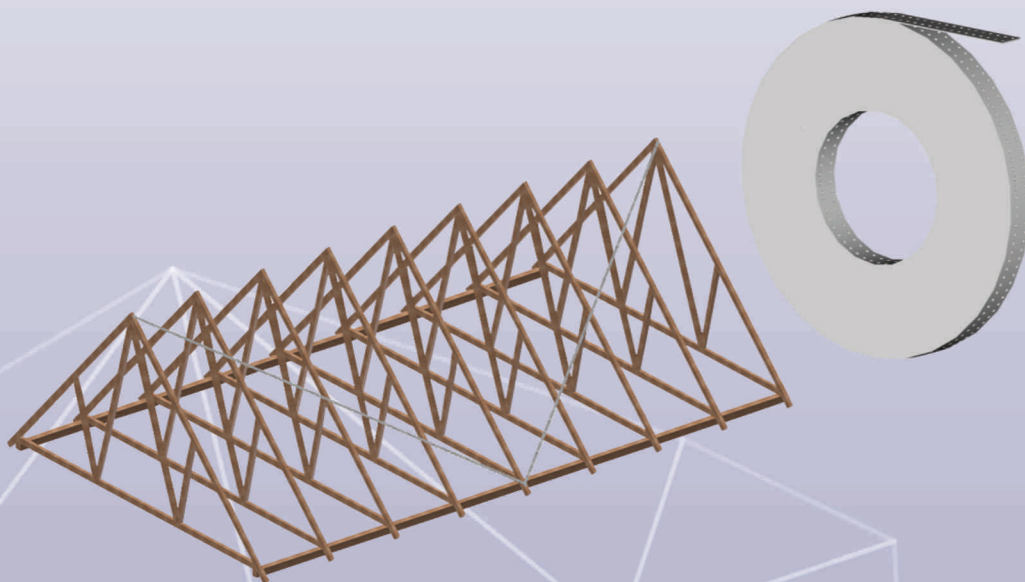

10 - 03 BRACKING STRAPS BV/ZP

width $W = 60$ mm
length $L = \text{dle dohody}$
material thickness $T = 2$ mm

ordering example :
bracking straps BV/ZP 10-03/L

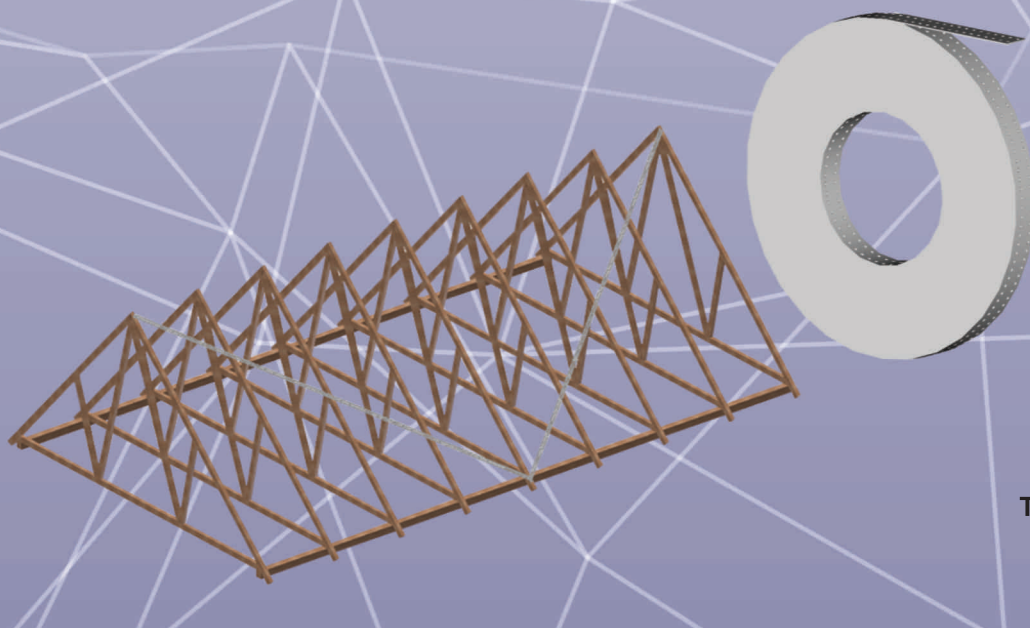

BRACKING STRAPS BV/ZP 10 - 04

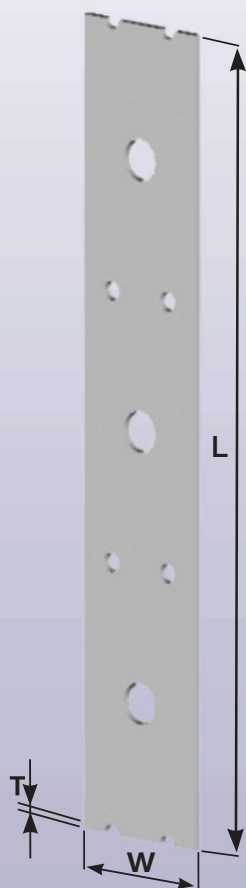

width $W = 40$ mm
length $L = \text{max. } 50$ m
material thickness $T = 2$ mm

ordering example :
bracking straps BV/ZP 10-04/L

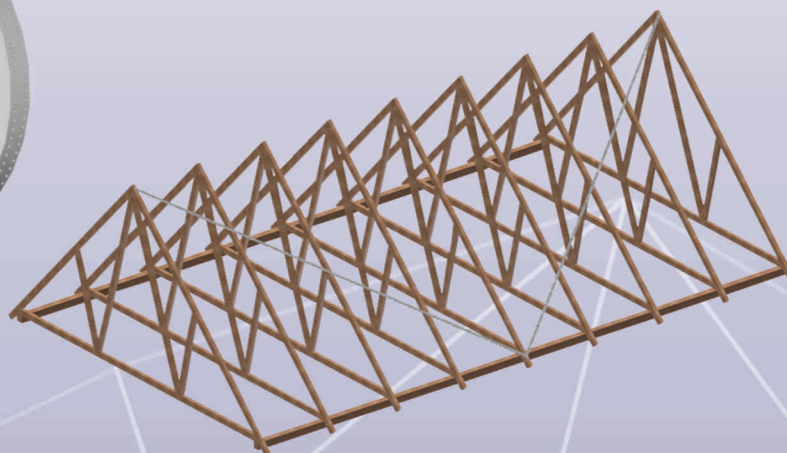

BRACKING STRAPS BV/ZP 10 - 05



width $W = 40$ mm
length $L = \text{max. } 50$ m
material thickness $T = 2$ mm

ordering example :
bracking straps BV/ZP 10-06/L

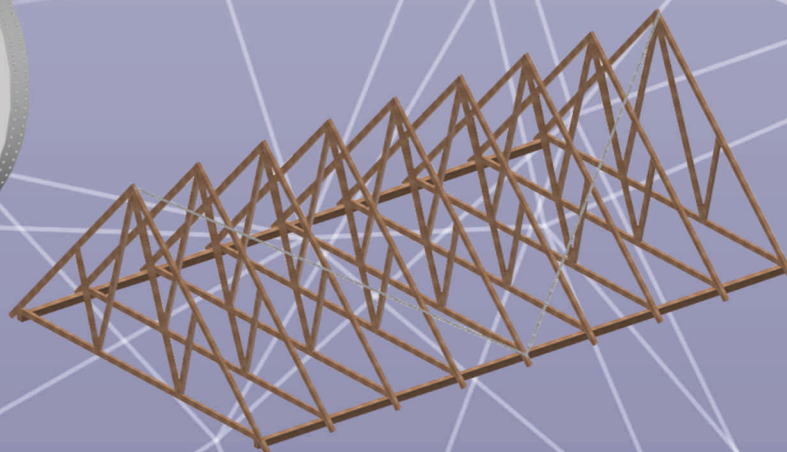

10 - 06 BRACKING STRAPS BV/ZP

width $W = 28$ mm
length $L =$ according to order
material thickness $T = 1,5$ mm

ordering example :
bracking straps BV/ZP 10-06/L

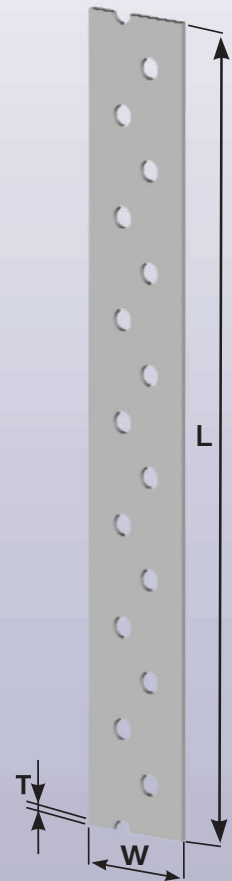
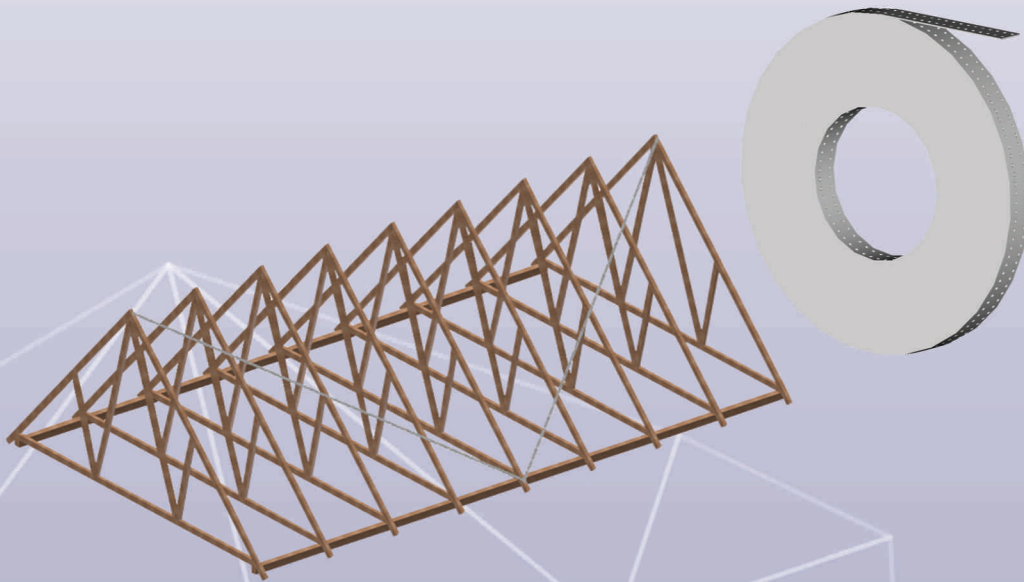

10 - 07 BRACKING STRAPS BV/ZP

width $W = 40$ mm
length $L =$ according to order
material thickness $T = 3$ mm

ordering example :
bracking straps BV/ZP 10-07/L

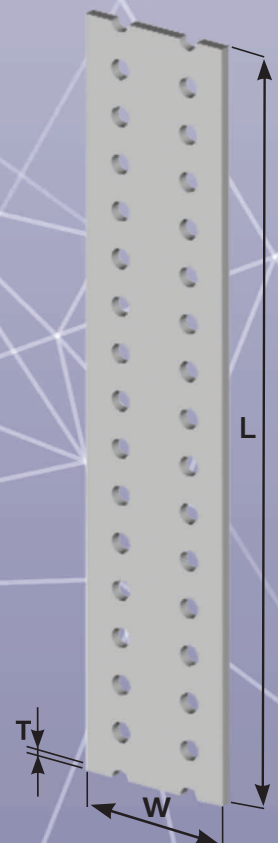
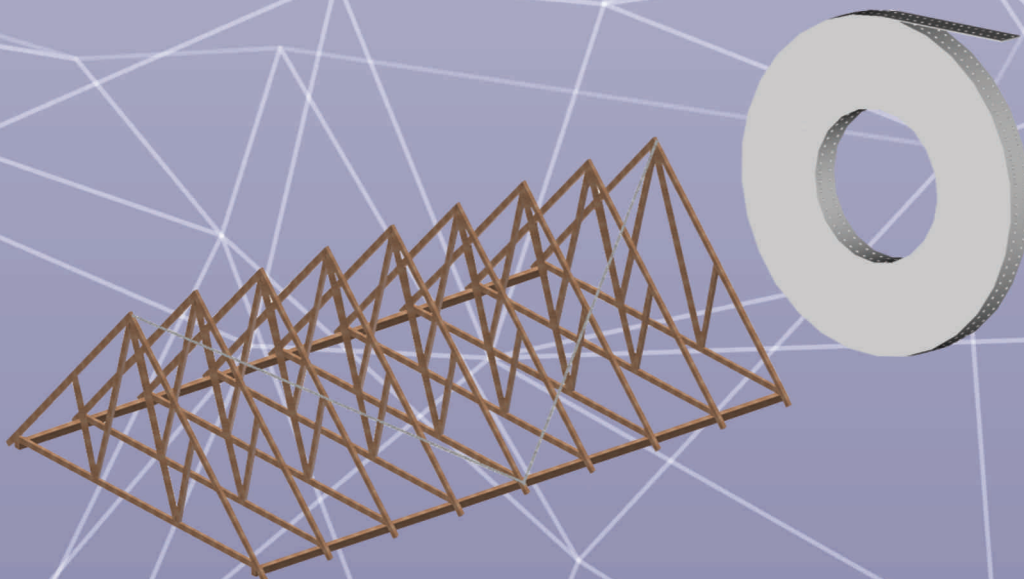

ASSEMBLY TAPE BV/MP 10 - 20



width $W = 12 \text{ mm}$
length $L =$ according to order
material thickness $T = 1 \text{ mm}$

ordering example :
assembly tape BV/MP 10-20/L

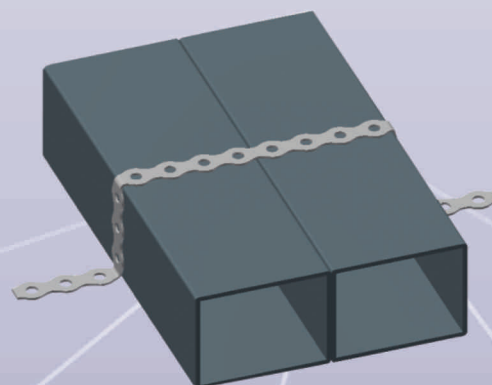
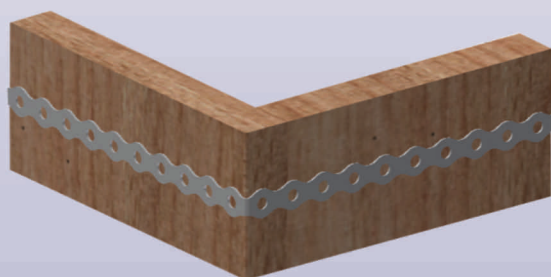

BRACKING STRAPS TENSIONER



Bracking straps tensioner
BOVA BV / ZP 10-01, 10-02, 10-03, 10-04, 10-05, 10-07

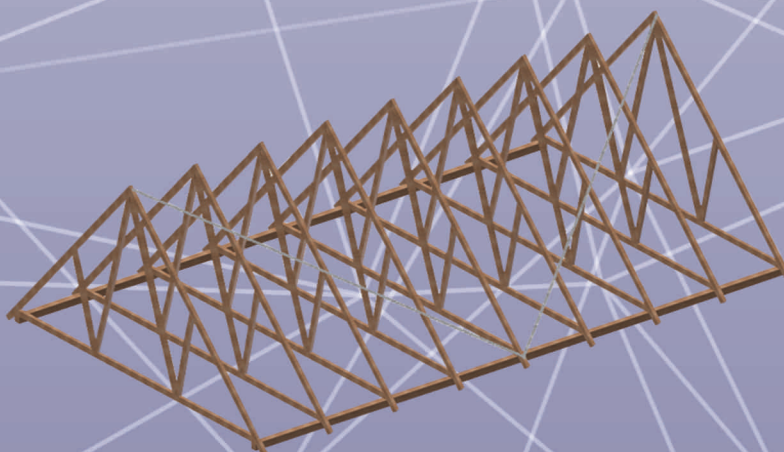

11 - 20 JOIST HANGER BV/T - P, L

Dimension	A	B	C	D	E	T
	30	80	80	40	40	2
	30	100	80	40	40	2
	30	120	80	40	40	2
	30	140	80	40	40	2
	30	160	80	40	40	2
	30	180	80	40	40	2
	30	200	80	40	40	2
	30	220	80	40	40	2

ordering example :
joist hanger BV/T 11-20/B

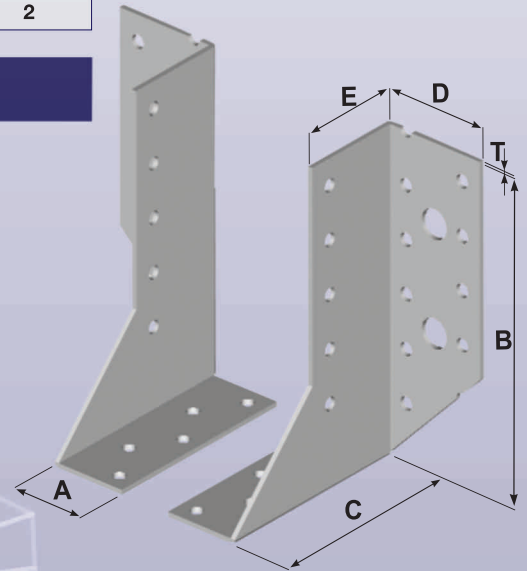
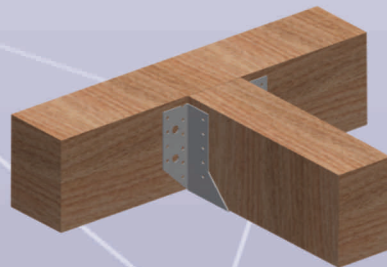

11 - 21 JOIST HANGER BV/T - 40

Dimension	A	B	C	D	E	T
40 x 60	40	60	80	40	40	2
40 x 80	40	80	80	40	40	2
40 x 100	40	100	80	40	40	2
40 x 120	40	120	80	40	40	2

ordering example :
joist hanger BV/T 11-21/B

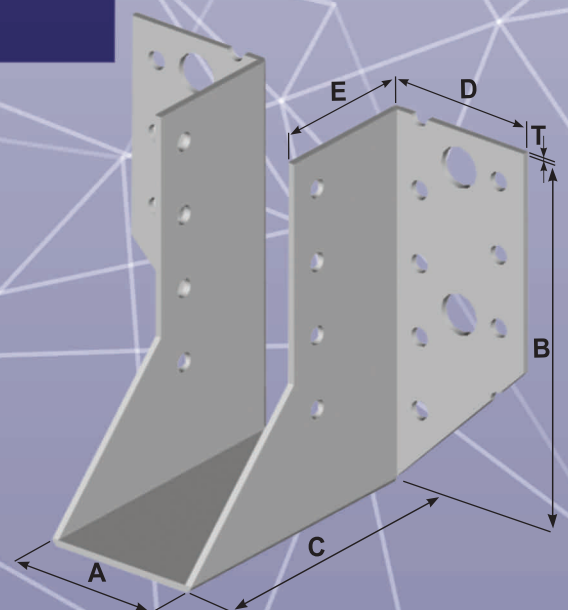
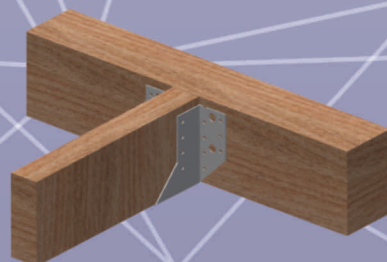

JOIST HANGER BV/T - 50 11 - 22

Dimension	A	B	C	D	E	T
50 x 85	50	85	80	40	40	2
50 x 105	50	105	80	40	40	2
50 x 125	50	125	80	40	40	2
50 x 145	50	145	80	40	40	2
50 x 165	50	165	80	40	40	2

ordering example :
joist hanger BV/T 11-22/B

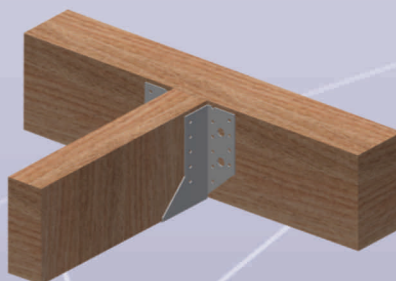
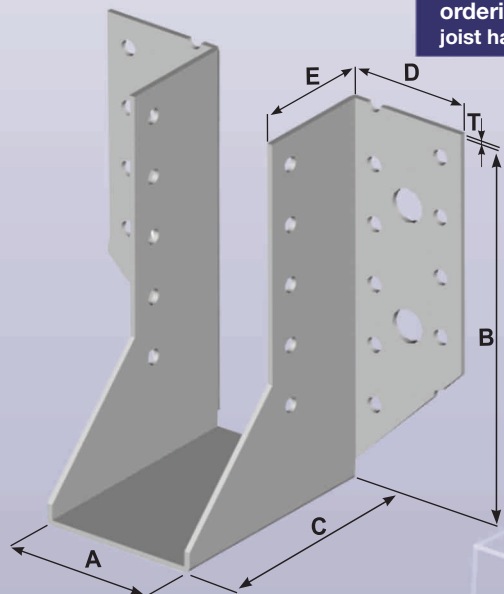

JOIST HANGER BV/T - 60 11 - 23

Dimension	A	B	C	D	E	T
60 x 80	60	80	80	40	40	2
60 x 100	60	100	80	40	40	2
60 x 120	60	120	80	40	40	2
60 x 140	60	140	80	40	40	2
60 x 160	60	160	80	40	40	2

ordering example :
joist hanger BV/T 11-23/B

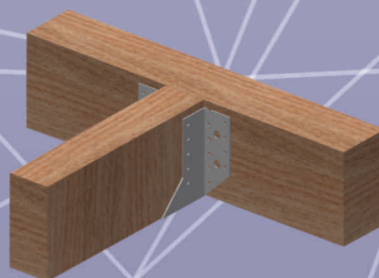
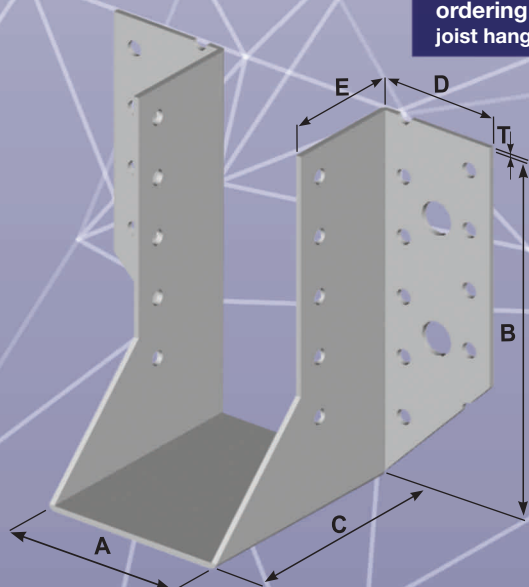

11 - 24 JOIST HANGER BV/T - 70

Dimension	A	B	C	D	E	T
70 x 105	70	105	80	40	40	2
70 x 125	70	125	80	40	40	2
70 x 145	70	145	80	40	40	2
70 x 165	70	165	80	40	40	2

ordering example :
joist hanger BV/T 11-24/B

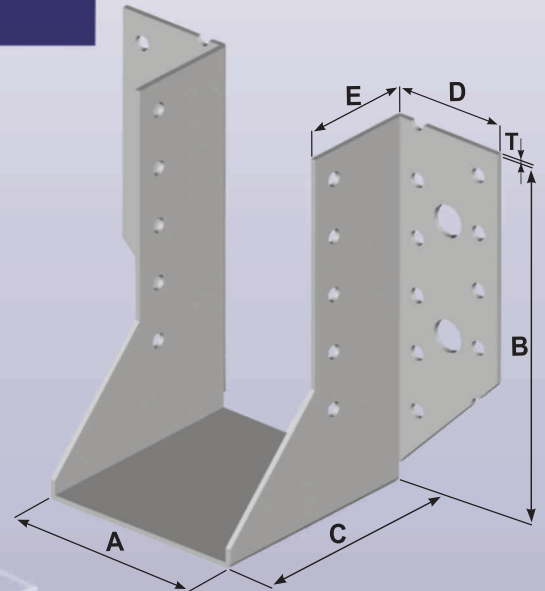
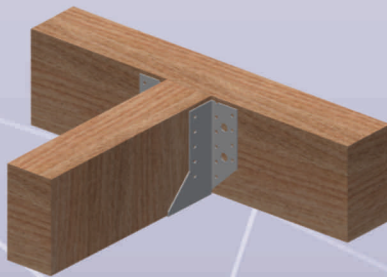

11 - 25 JOIST HANGER BV/T - 80

Dimension	A	B	C	D	E	T
80 x 80	80	80	80	40	40	2
80 x 100	80	100	80	40	40	2
80 x 120	80	120	80	40	40	2
80 x 140	80	140	80	40	40	2
80 x 160	80	160	80	40	40	2
80 x 200	80	200	80	40	40	2

ordering example : joist hanger BV/T 11-25/B
variation: external, internal

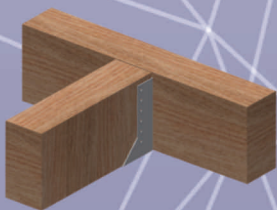

variation internal

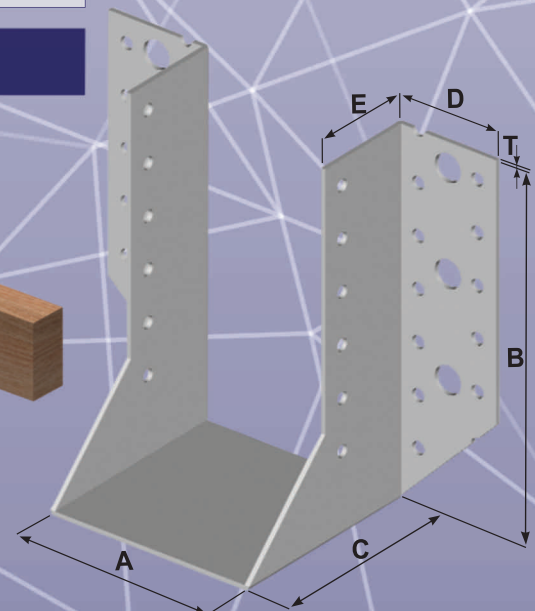
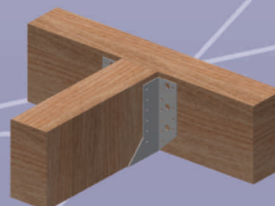
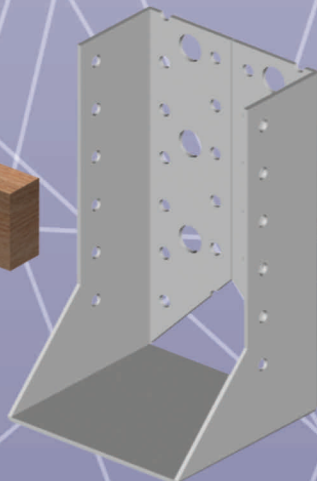

JOIST HANGER BV/T - 90 11 - 26

Dimension	A	B	C	D	E	T
90 x 85	90	85	80	40	40	2
90 x 105	90	105	80	40	40	2
90 x 125	90	125	80	40	40	2
90 x 145	90	145	80	40	40	2
90 x 165	90	165	80	40	40	2

ordering example : joist hanger BV/T 11-26/B
variation: external, internal

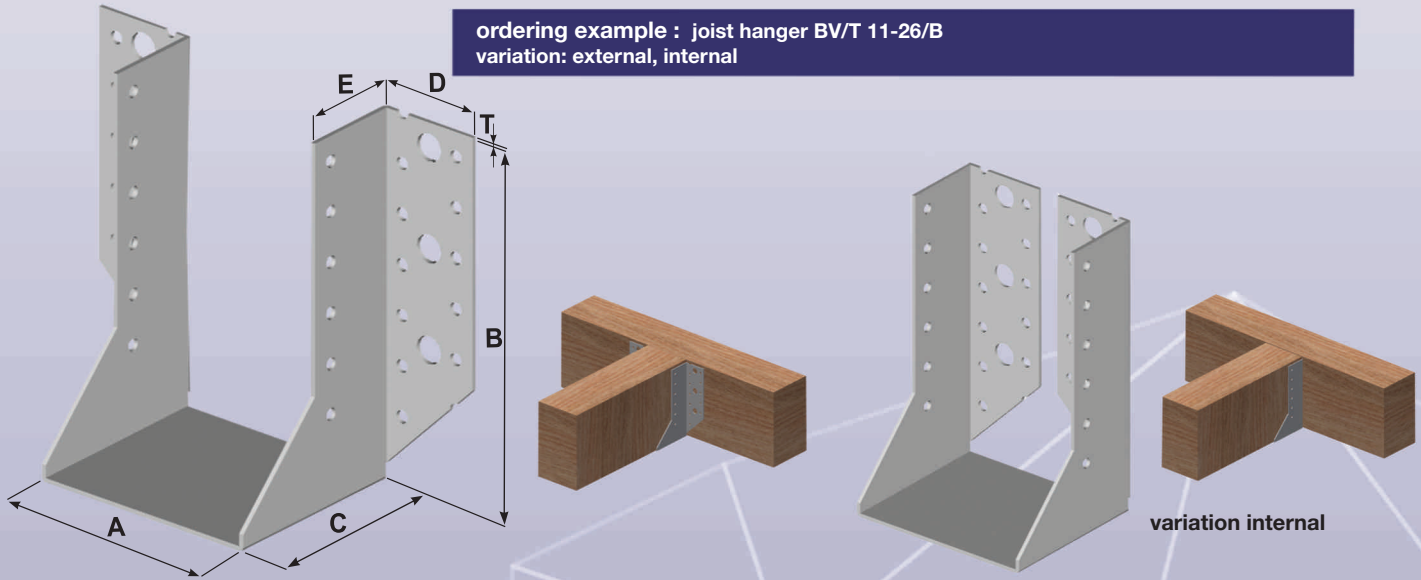

JOIST HANGER BV/T - 100 11 - 27

Dimension	A	B	C	D	E	T
100 x 100	100	100	80	40	40	2
100 x 120	100	120	80	40	40	2
100 x 140	100	140	80	40	40	2
100 x 160	100	160	80	40	40	2
100 x 200	100	200	80	40	40	2

ordering example : joist hanger BV/T 11-27/B
variation: external, internal

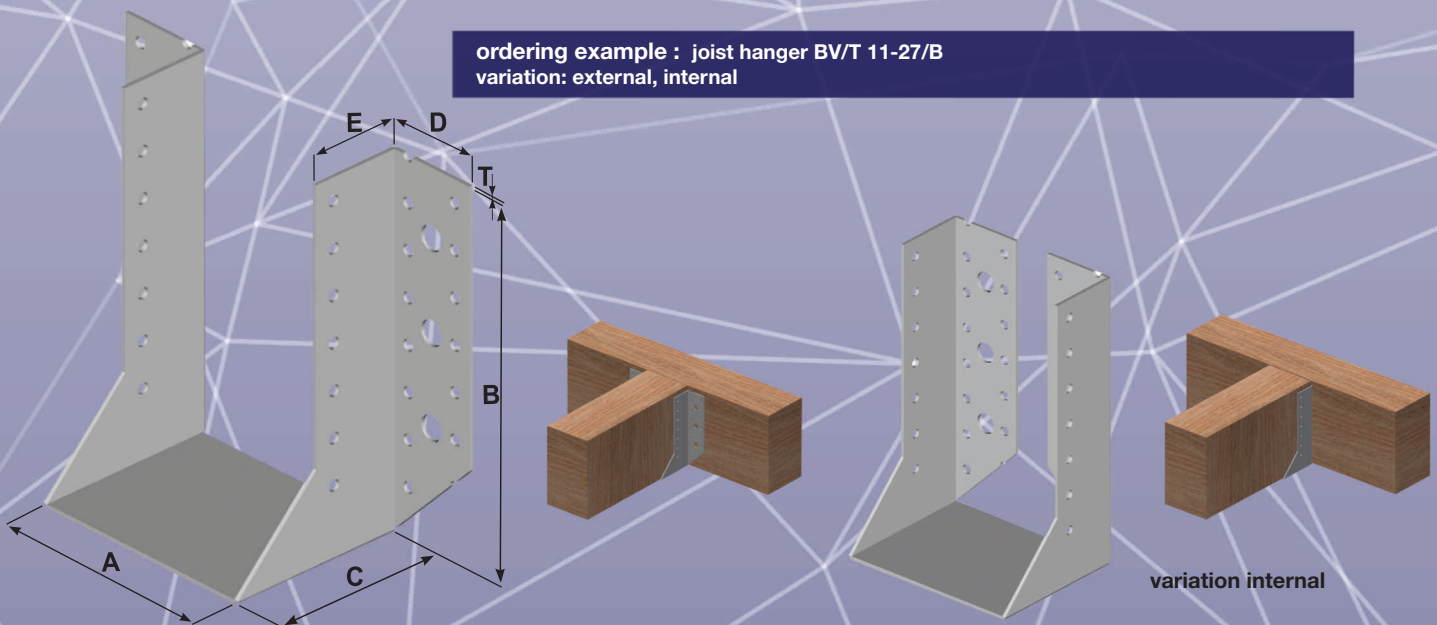

11 - 29 JOIST HANGER BV/T - 120

Dimension	A	B	C	D	E	T
120 x 120	120	120	80	40	40	2
120 x 140	120	140	80	40	40	2
120 x 160	120	160	80	40	40	2
120 x 200	120	200	80	40	40	2
120 x 240	120	240	80	40	40	2

ordering example : joist hanger BV/T 11-29/B
variation: external, internal

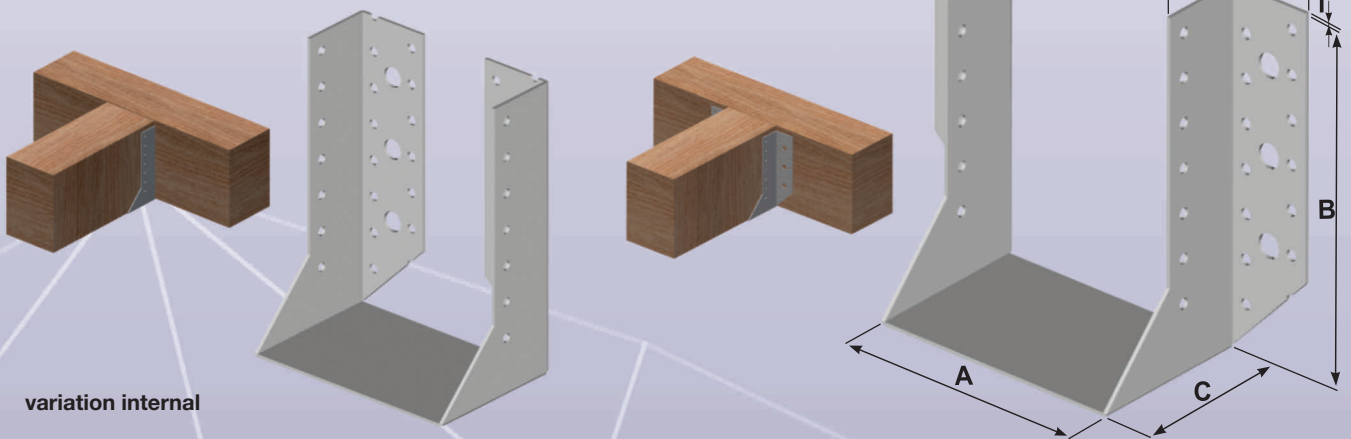

11 - 31 JOIST HANGER BV/T - 140

Dimension	A	B	C	D	E	T
140 x 140	140	140	80	40	40	2
140 x 160	140	160	80	40	40	2
140 x 200	140	200	80	40	40	2
140 x 240	140	240	80	40	40	2

ordering example : joist hanger BV/T 11-31/B
variation: external, internal

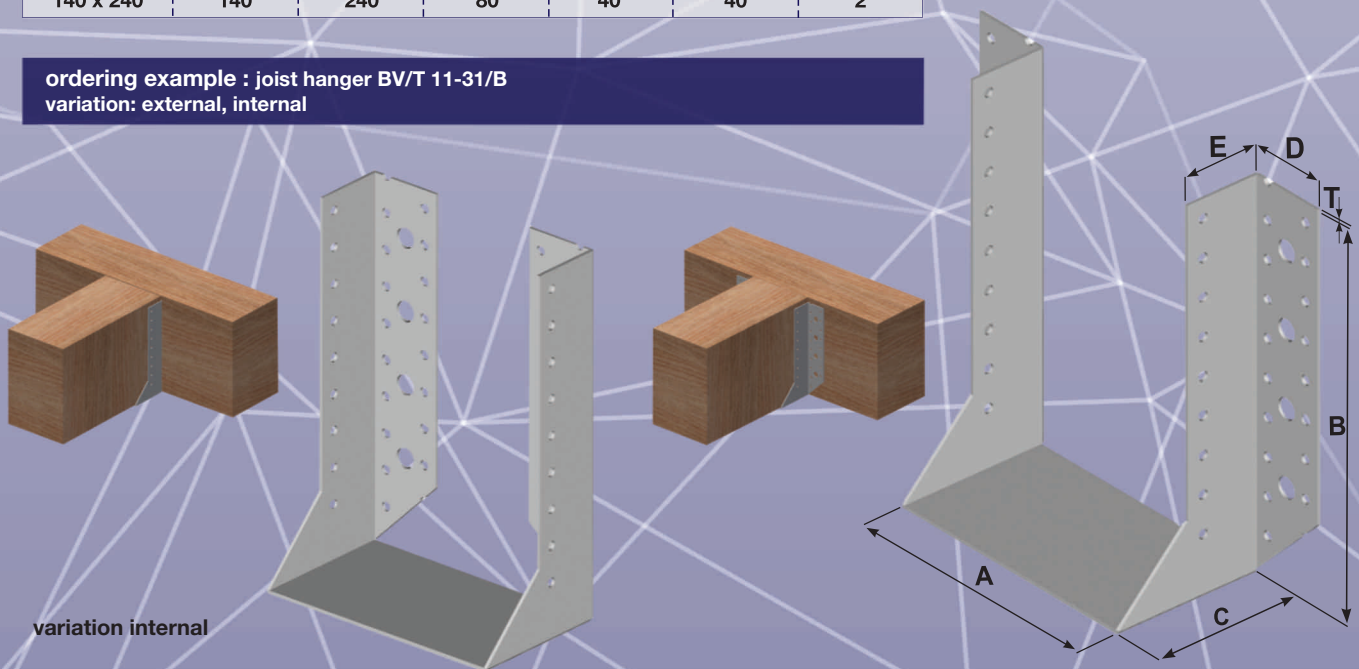

JOIST HANGER BV/T WITH UPPER FLEX 11 - 32

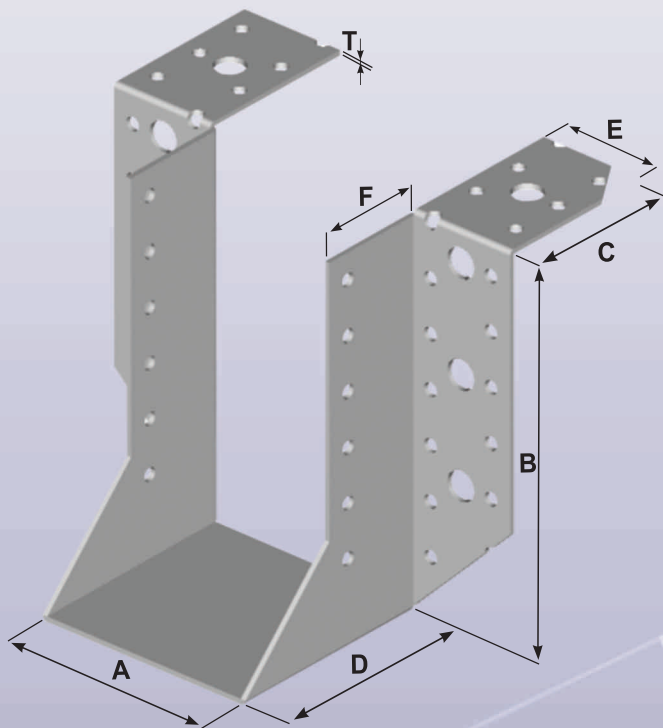

width A = 40, 50, 60, 70, 80, 90, 100, 120, 140 mm
 height B = 160, 200, 240, 300, 360, 400 mm
 rameno C = 60 mm
 dimension D = 80 mm
 dimension E = 40 mm
 dimension F = 40 mm
 material thickness T = 2 mm

ordering example :
 joist hanger BV/T 11-32 / A x B x C

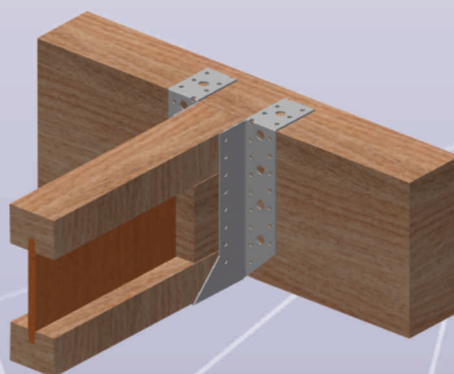

JOIST HANGER BV/T - 160 11 - 33

Dimension	A	B	C	D	E	T
160 x 140	160	140	80	40	40	2
160 x 160	160	160	80	40	40	2
160 x 200	160	200	80	40	40	2
160 x 240	160	240	80	40	40	2
160 x 280	160	280	80	40	40	2

ordering example : joist hanger BV/T 11-33/B
 variation: external, internal

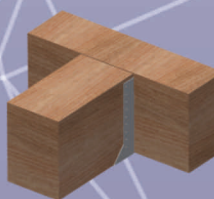
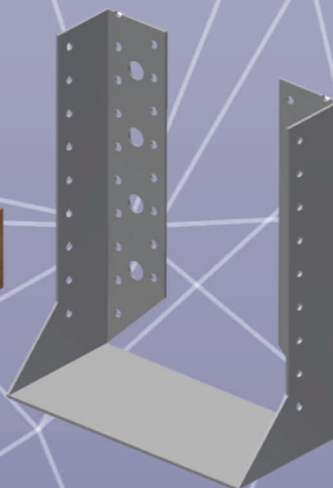
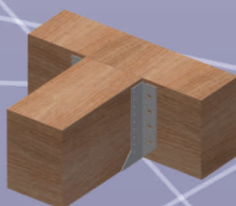
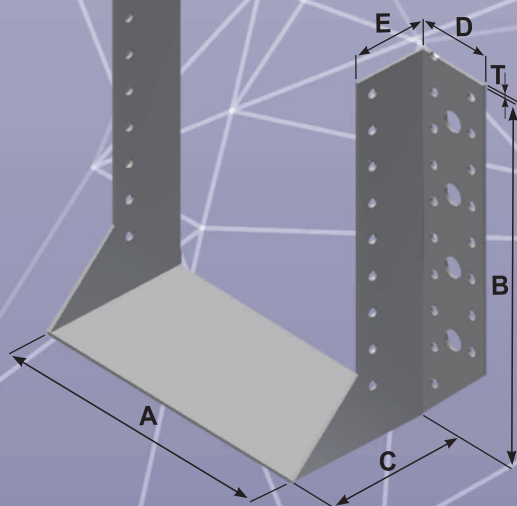

variation internal

11 - 40 JOIST HANGER BV/T

for width A = 60, 80, 100, 120, 140, 160, 180, 200 mm
height B = 120, 140, 160, 180, 200, 220, 240, 260, 280, 300, 320 mm
for width A = 90 mm
height B = 125, 145, 165, 185, 205, 225, 245, 265, 285, 305, 325 mm
dimension C = 40 mm
dimension D = 70 mm
material thickness T = 3 mm

ordering example :
joist hanger BV/T 11- 40 / A x B

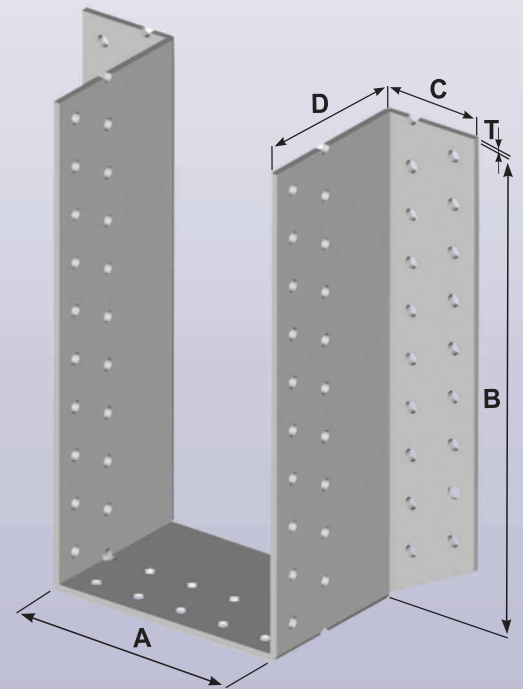
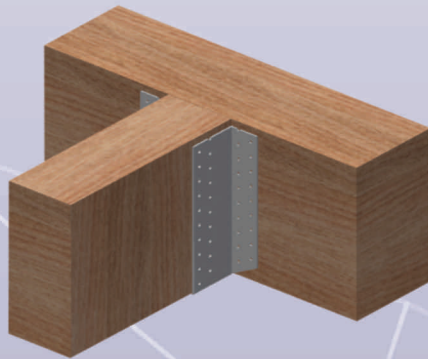

11 - 41 JOIST HANGER BV/T

for width A = 80, 100, 120, 140, 160, 180, 200 mm
height B = 120, 140, 160, 180, 200, 220, 240, 260, 280, 300, 320 mm
for width A = 90 mm
height B = 125, 145, 165, 185, 205, 225, 245, 265, 285, 305, 325 mm
dimension C = 40 mm
dimension D = 70 mm
material thickness T = 3 mm

ordering example :
joist hanger BV/T 11- 41 / A x B

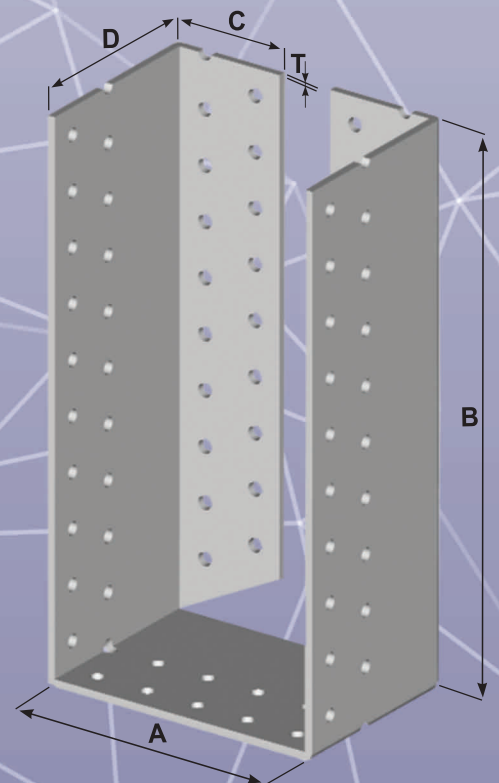
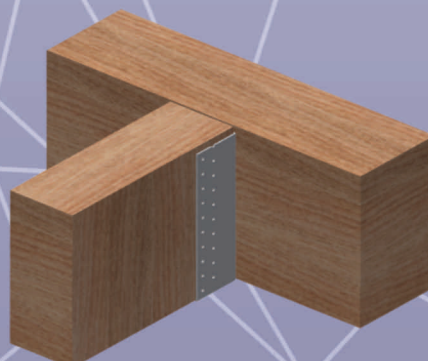

JOIST HANGER BV/T 11 - 42

for width A = 60, 80, 100, 120, 140, 160, 180, 200 mm
 height B = 120, 140, 160, 180, 200, 220, 240, 260, 280, 300, 320 mm
 for width A = 90 mm
 height B = 125, 145, 165, 185, 205, 225, 245, 265, 285, 305, 325 mm
 dimension C = 40 mm
 dimension D = 70 mm
 material thickness T = 3 mm

ordering example :
 joist hanger BV/T 11- 42 / A x B

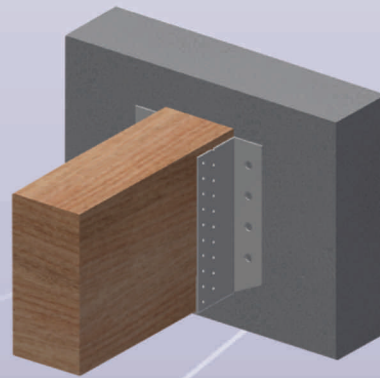
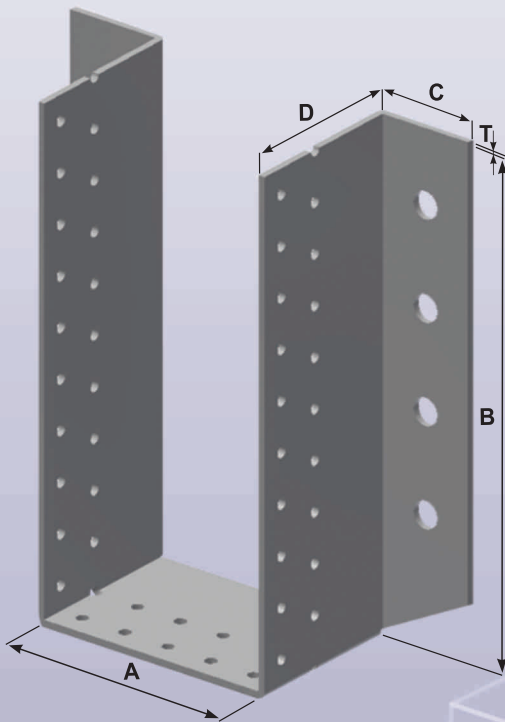

ANCHOR ELEMENT BV/KP 12 - 01

Dimension	W	L	L1	T
	40	205	65	5

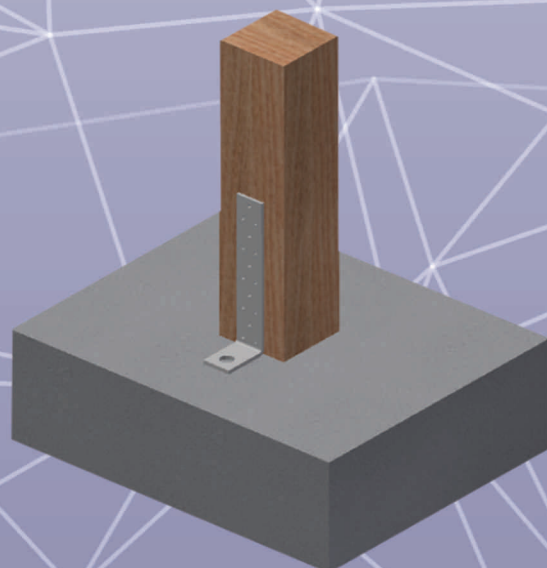
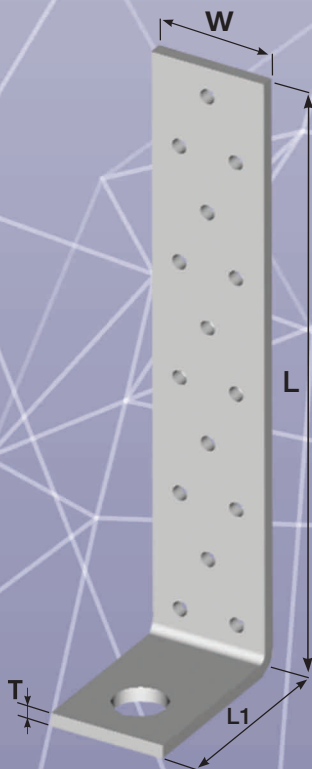

12 - 02 ANCHOR ELEMENT BV/KP

Dimension	W	L	T
	40	200	5

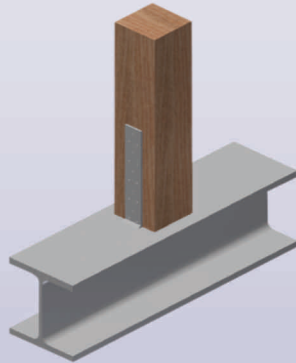

12 - 03 ANCHOR ELEMENT BV/KP

Dimension	W	L	A	T
	40	350	25	5

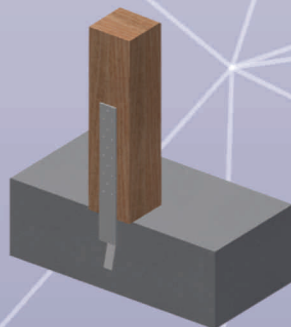

12 - 04 ANCHOR ELEMENT BV/KP

Dimension	W	L	T
	40	240	5

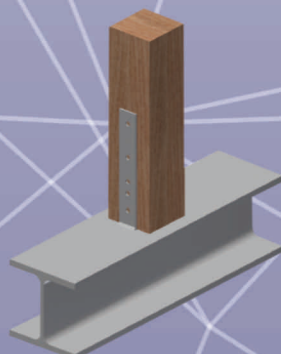

ANCHOR ELEMENT BV/KP

12 - 05



Dimension	W	L	L1	T
	40	245	65	5

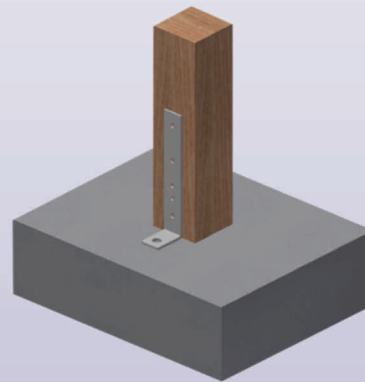

ANCHOR ELEMENT BV/KP

12 - 06



Dimension	W	L	A	T
	40	390	25	5

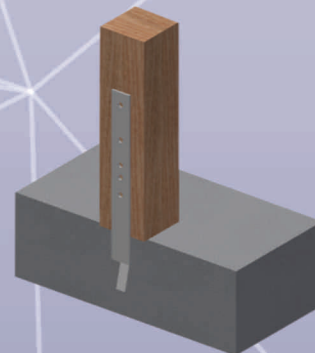

ANCHOR ELEMENT BV/KP

12 - 07

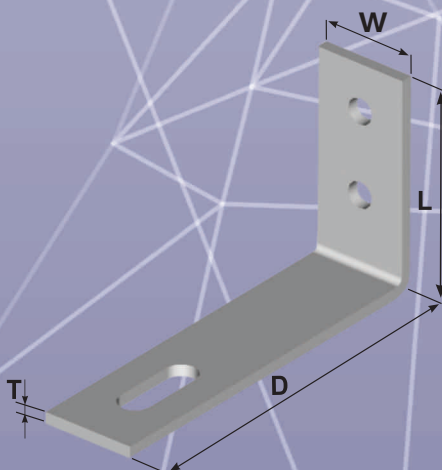

Dimension	W	L	D	T
	40	90	160	5
	40	90	300	5

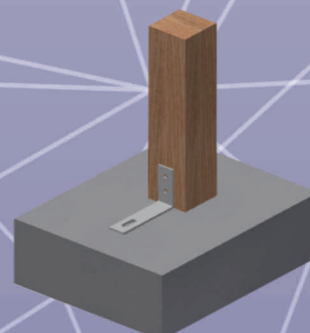

12 - 08 ANCHOR ELEMENT BV/KP

Dimension	W	L	A	B	T
	40	200	25	15	5

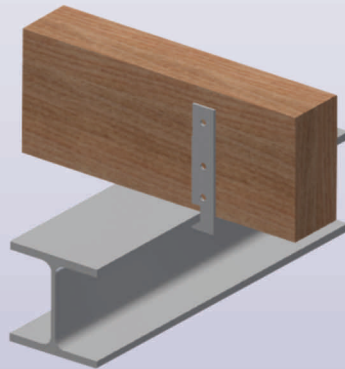

12 - 09 ANCHOR ELEMENT BV/KP

Dimension	W	L	A	B	T
	40	200	25	15	5

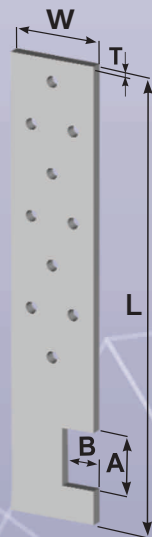
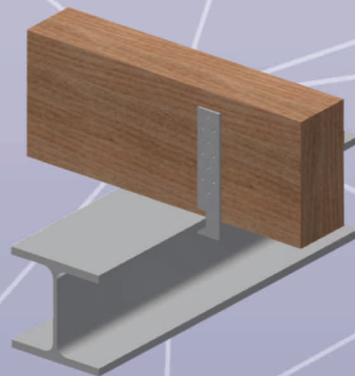

12 - 12 ANCHOR ELEMENT 60 x 240 x 175

Dimension	W	L	L1	T	T1
	60	260	175	2,5	20

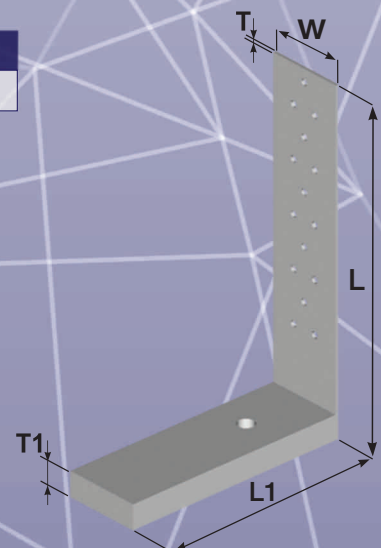
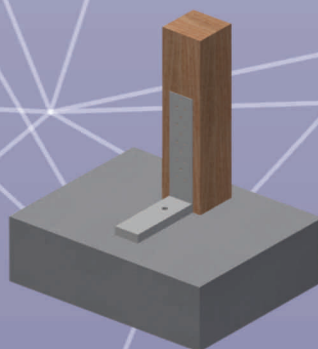

MOVABLE ANCHOR BV/KP 12 - 13

Dimension	W	L	L1	T
	90	95	95	3

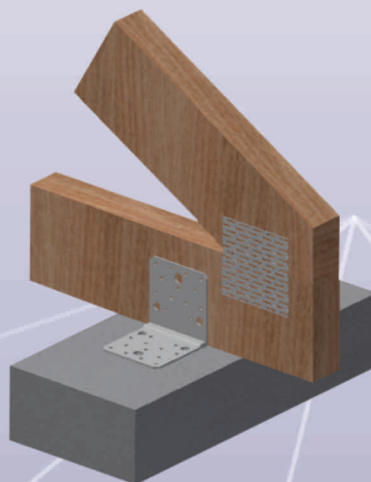
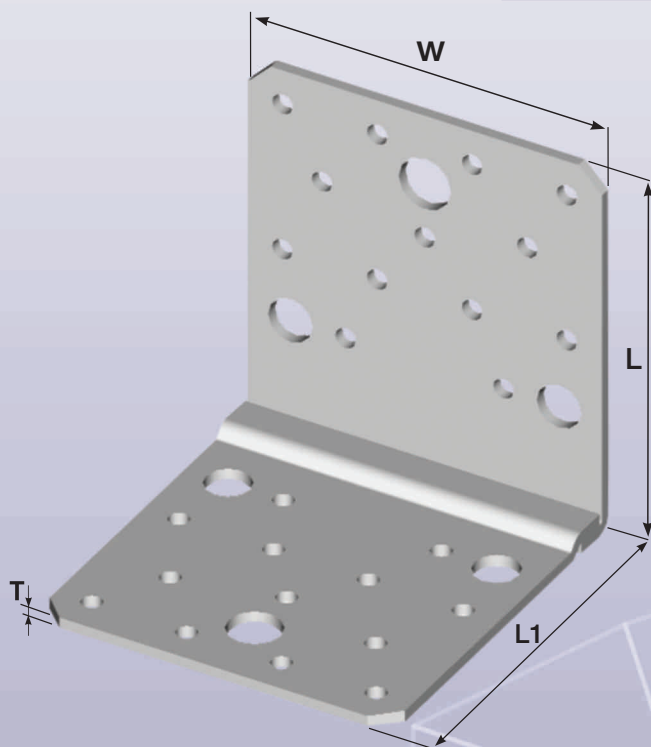

ANCHOR BV/KK 12 - 20

Dimension	B	L	H	T
60	64	300	140	2,5
80	84	300	140	2,5
100	104	280	140	2,5
120	124	260	140	2,5

ordering example :
anchor BV/KK 12 - 20/width

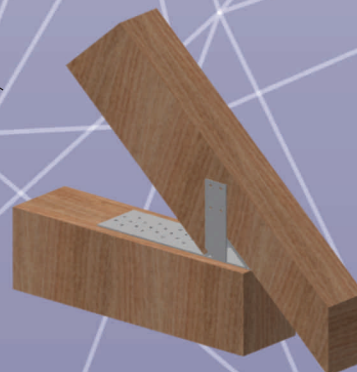
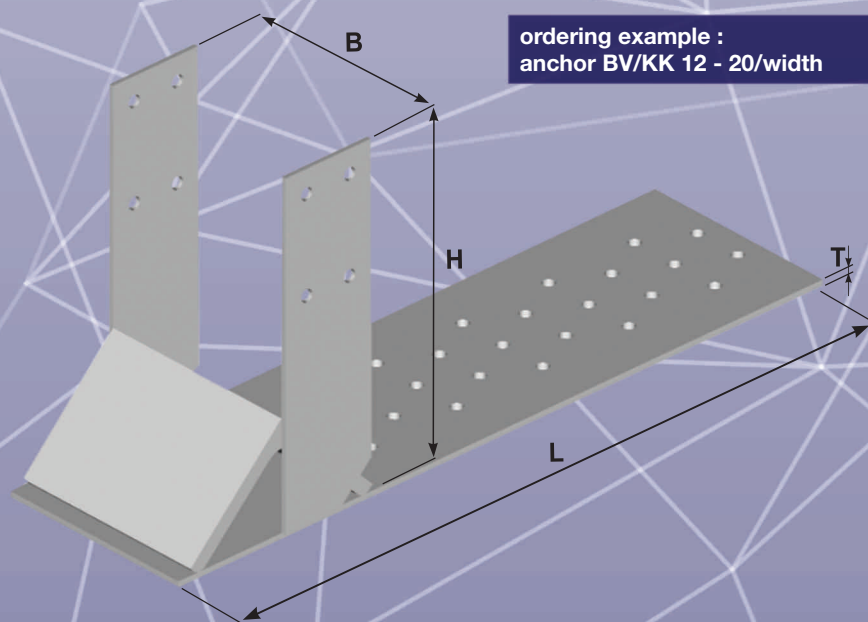

12 - 21 ANCHOR BV/KK

Dimension	B	L	H	D	T
60	64	170	140	200	2,5
80	84	170	140	220	2,5
100	104	170	140	240	2,5
120	124	170	140	260	2,5

ordering example :
anchor BV/KK 12 - 21/width

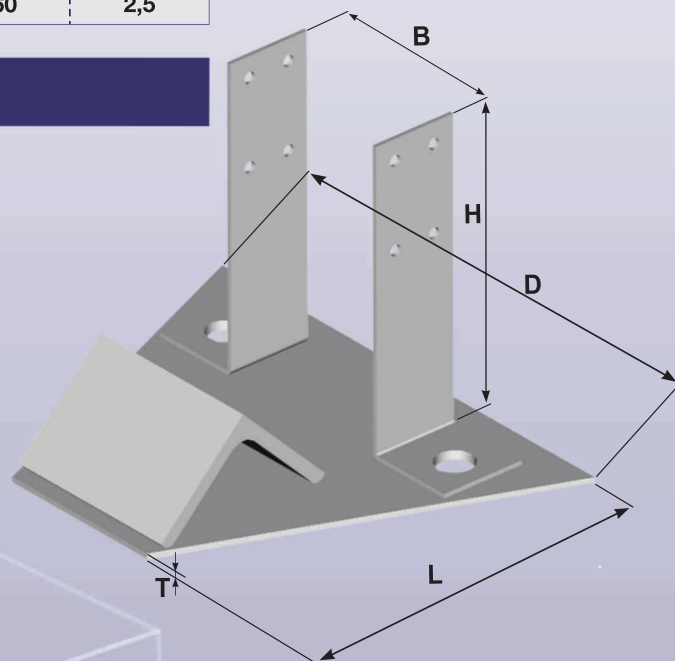
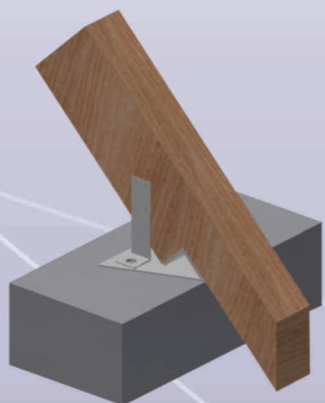

12 - 30 ANCHOR BV/KP

Dimension	W	H	D	T
	40	80	60	3
	40	120	60	3
	40	160	60	3
	40	200	60	3

ordering example :
anchor BV/KP 12 - 30/H

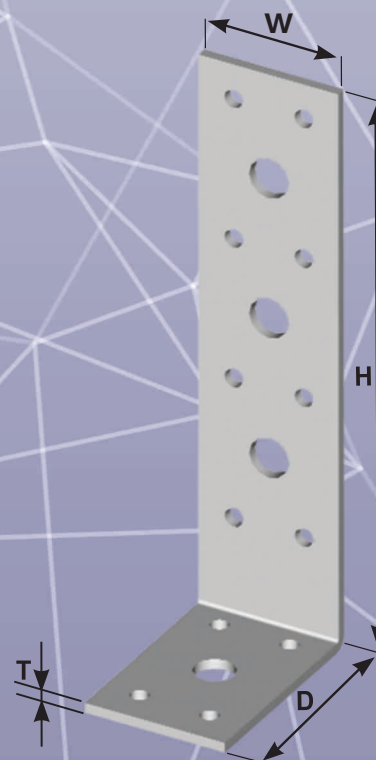
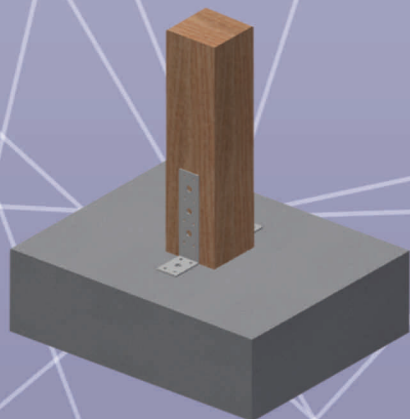

ANCHOR BV/KP 12 - 35

Dimension	W	L	L1	T
	65	95	105	4

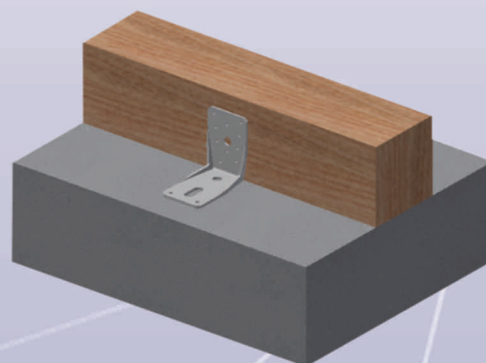
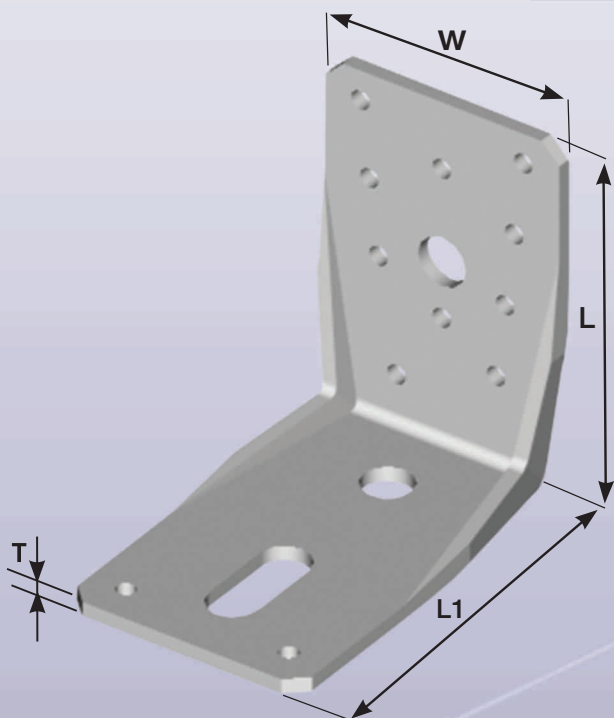

ANCHOR BV/KP 12 - 36

Dimension	W	L	L1	T
	65	135	105	4

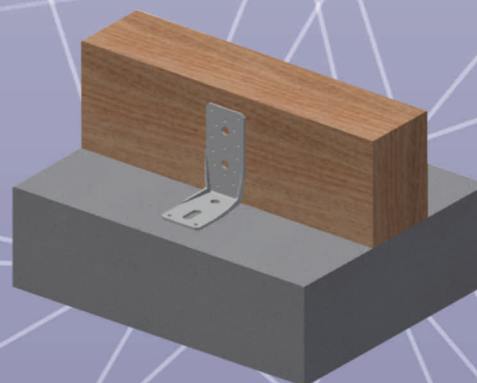
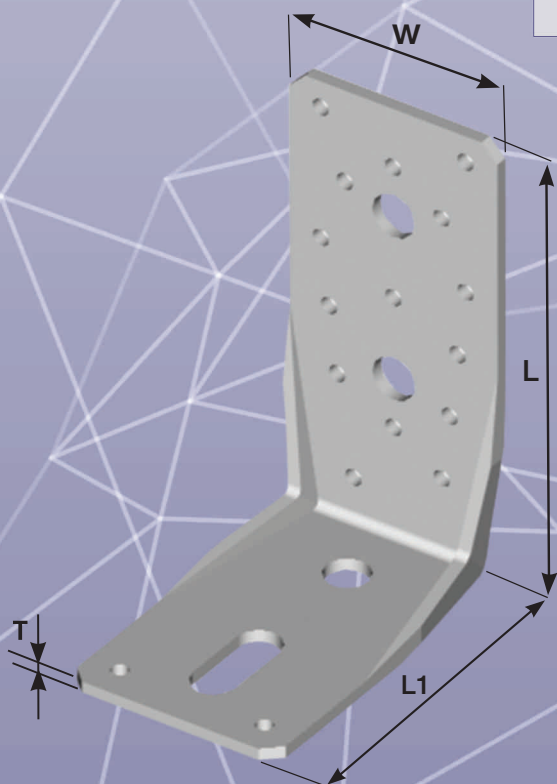

12 - 37 ANCHOR ELEMENT BV/KP

Dimension	W	L	L1	T
	65	285	105	4

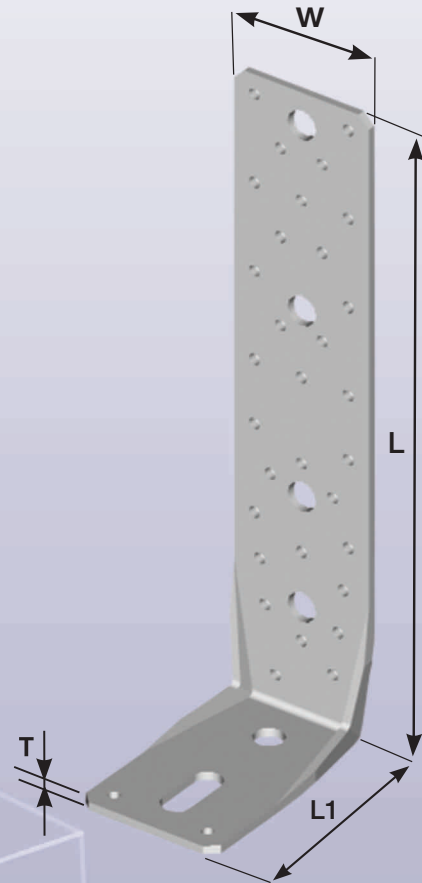
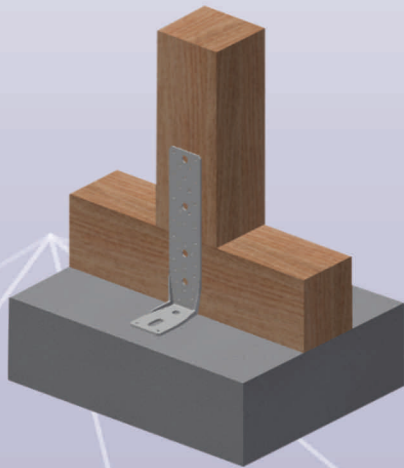

12 - 38 ANCHOR ELEMENT BV/KP

Dimension	W	L	L1	T
	80	95	85	4

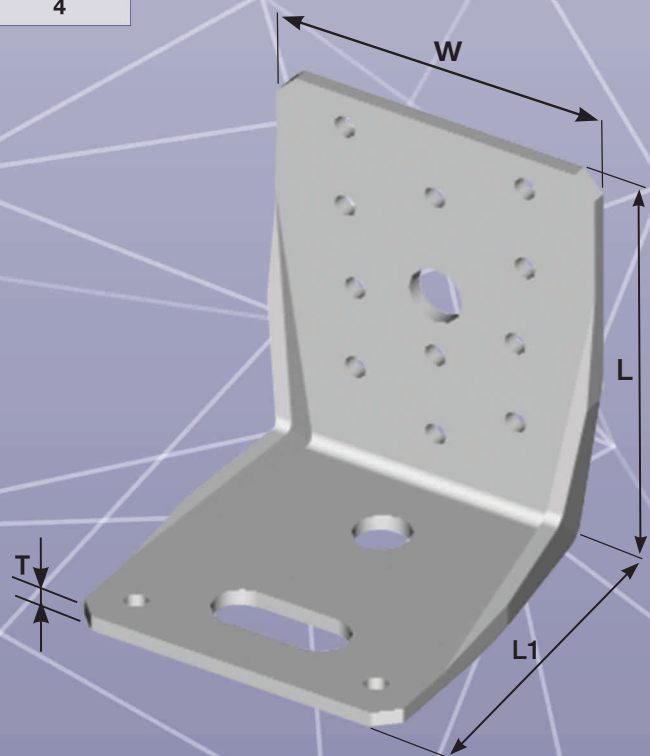
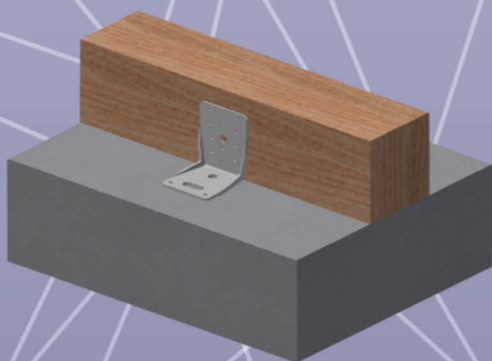

ANCHOR ELEMENT BV/KP 12 - 39

Dimension	W	L	L1	T
	80	135	85	4

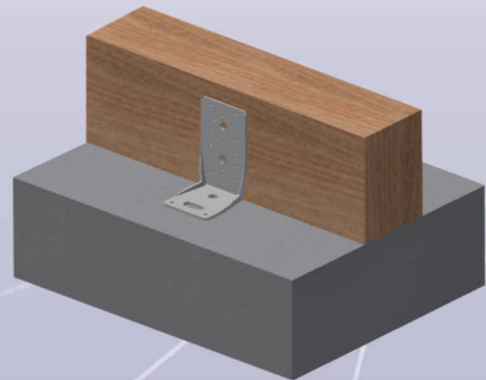
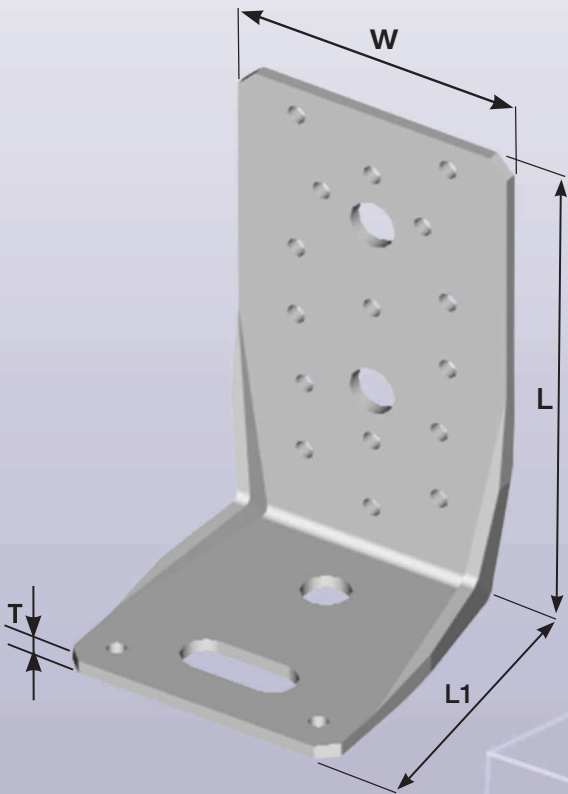

SLIDING ANCHOR 12 - 40

Anchor element

Dimension	A	B	H	T
	80	45	95	4
	80	45	135	4

Sliding plate

Dimension	W	L	T1
	50	300	2
	60	300	2
	80	300	2

ordering example :
sliding anchor 12-40/anchor element height H, sliding plate width W

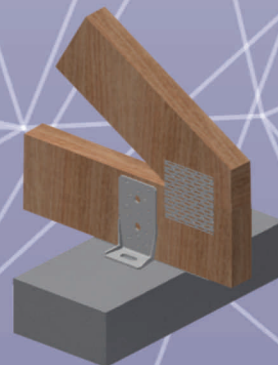
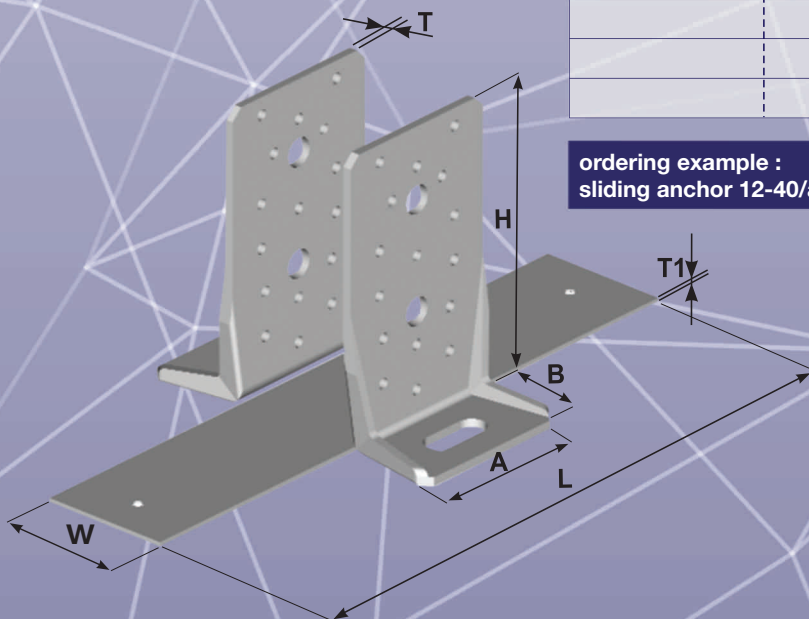

12 - 41 ANCHOR ELEMENT BV/KP

Dimension	W	L	L1	T
	65	135	65	3

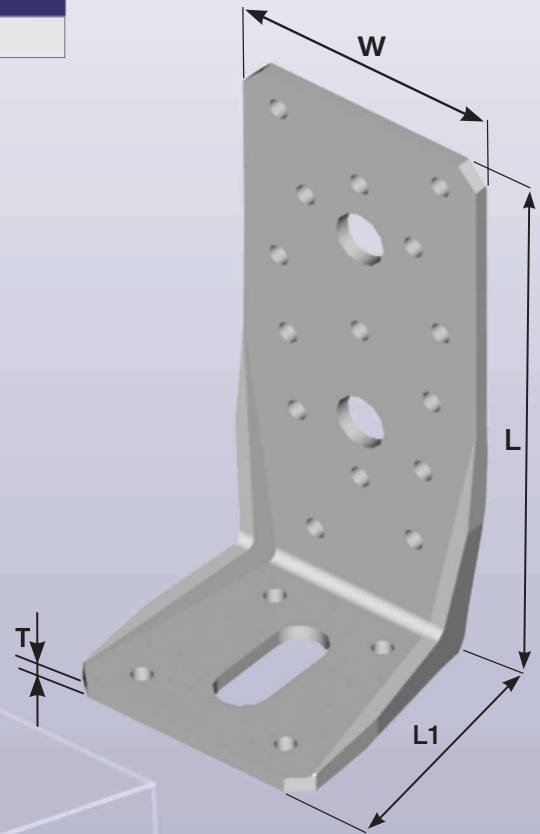
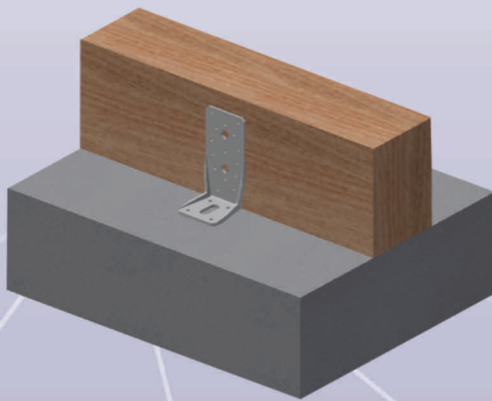

12 - 42 ANCHOR ELEMENT BV/KP

Dimension	W	L	L1	T
	65	95	105	3

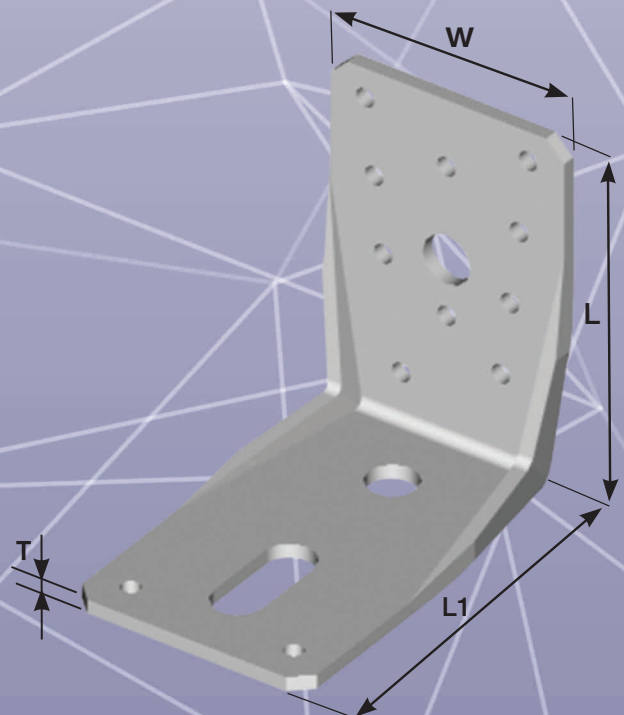
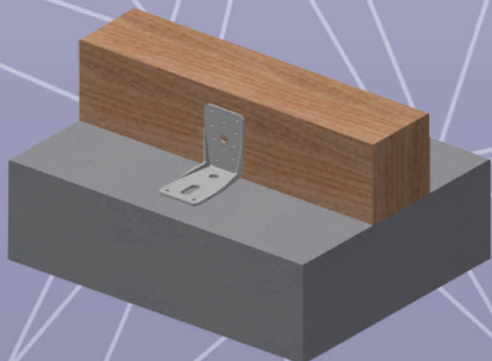

ANCHOR ELEMENT BV/KP 12 - 43

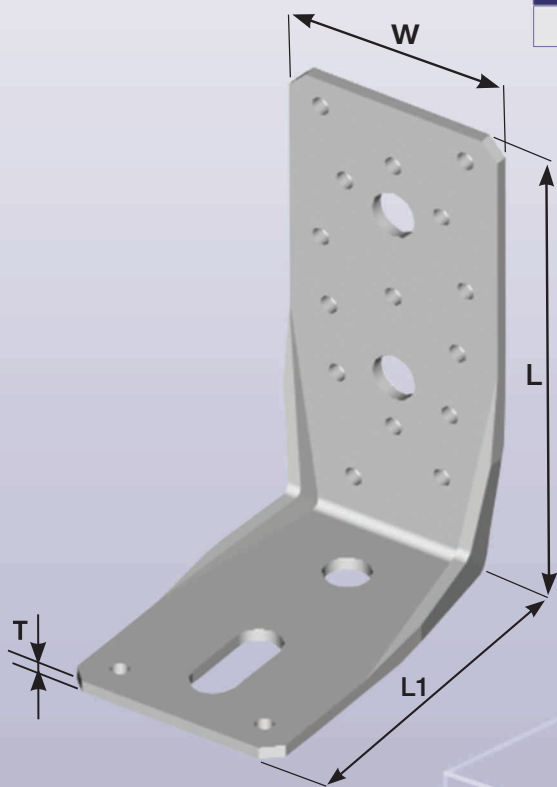

Dimension	W	L	L1	T
	65	135	105	3

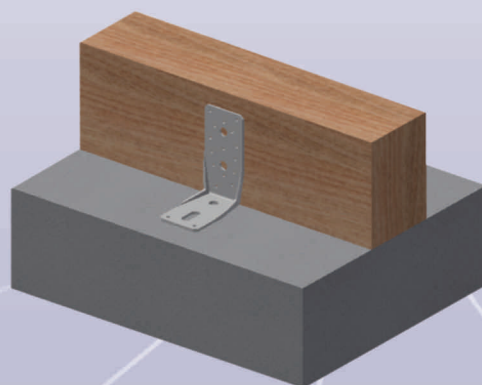

ANCHOR ELEMENT BV/KP 12 - 44

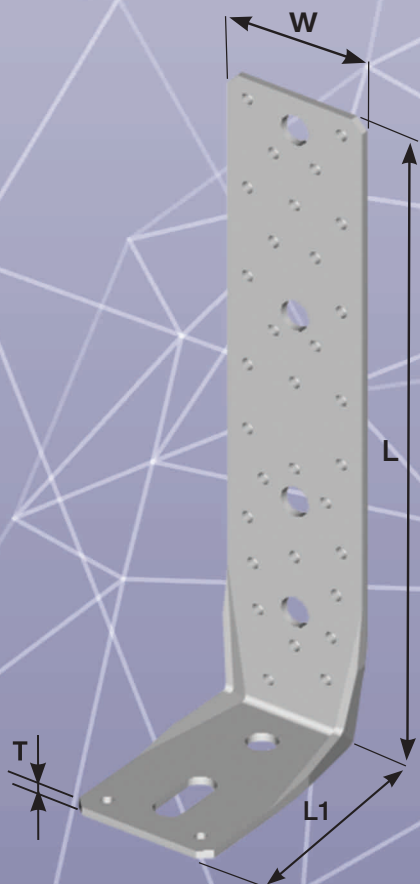

Dimension	W	L	L1	T
	65	285	105	3

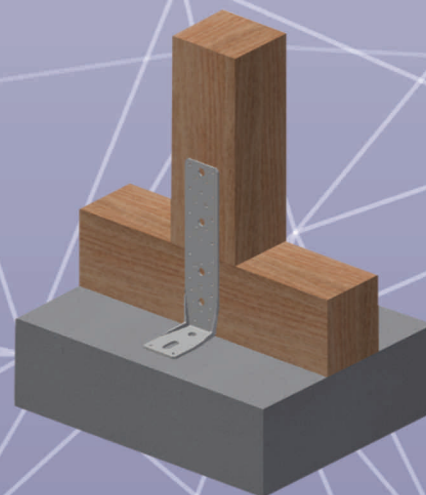

12 - 45 ANCHOR ELEMENT BV/KP

Dimension	W	L	L1	T
	80	95	85	3

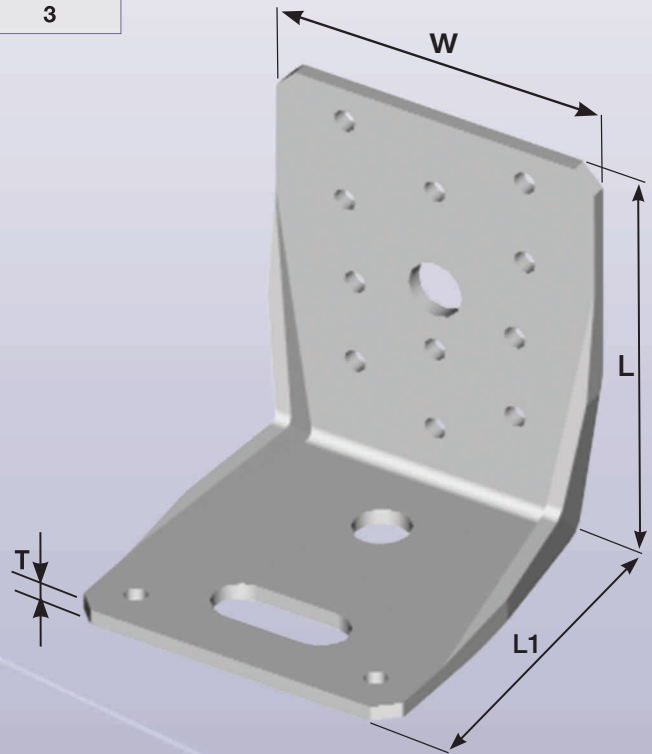
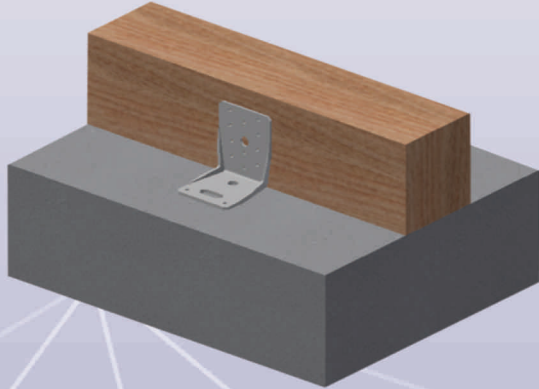

12 - 46 ANCHOR ELEMENT BV/KP

Dimension	W	L	L1	T
	80	135	85	3

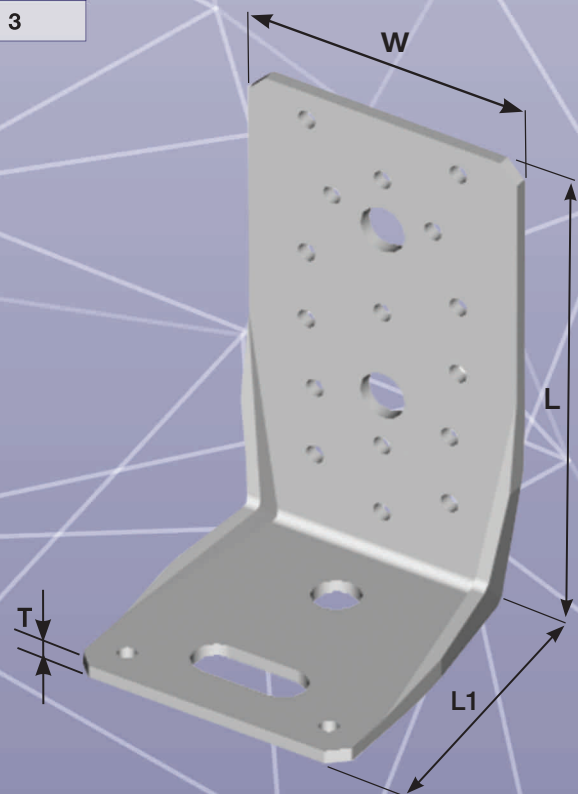
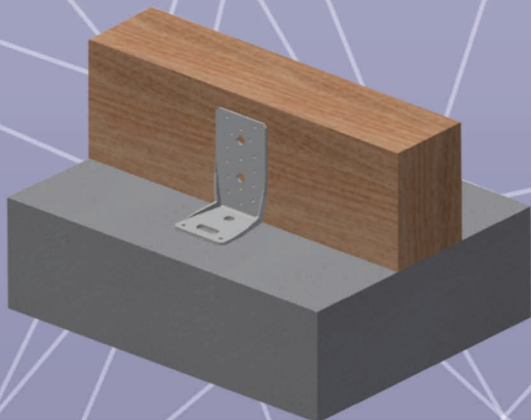

ANCHOR ELEMENT BV/KP 12 - 47

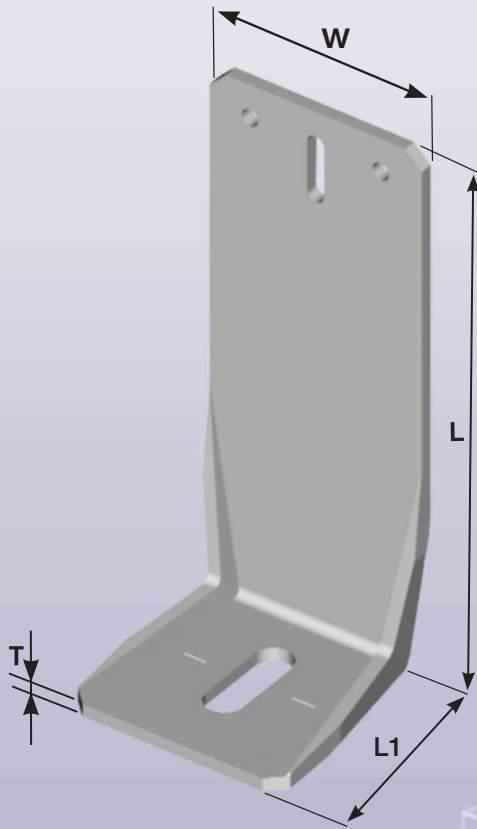

length L = 65, 80, 100, 120, 140, 160, 180, 200, 220, 240, 260, 280, 300 mm
 length L1 = 65 mm
 width W = 65 mm
 material thickness T = 3 mm

ordering example :
 anchor element BV/KP 12-47/L

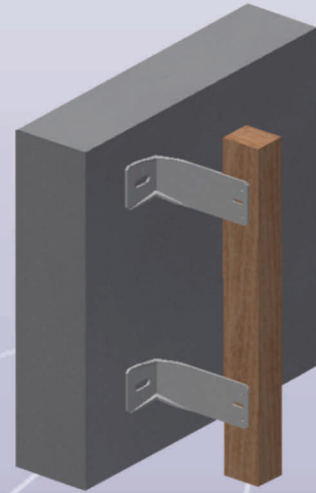

ANCHOR ELEMENT BV/KP 12 - 51

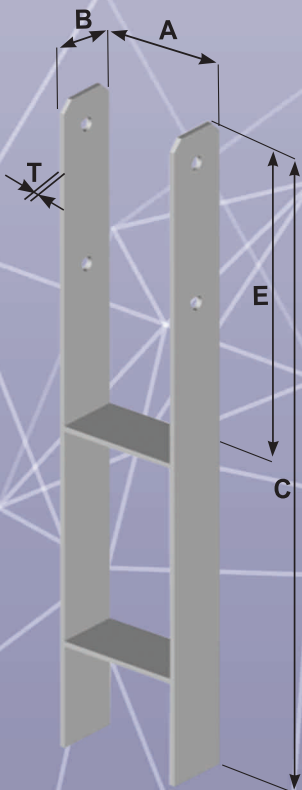

Dimension	A	B	C	E	T
	115	60	600	300	5

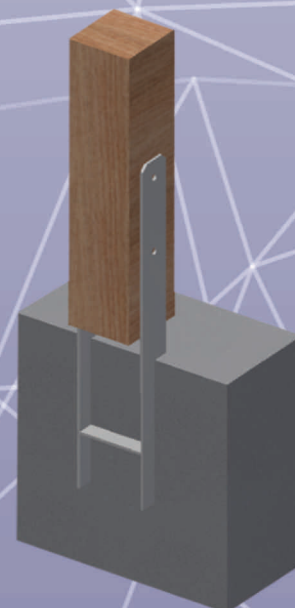

12 - 52 ANCHOR ELEMENT BV/KP

Dimension	A	B	C	E	T
	90	60	600	300	5

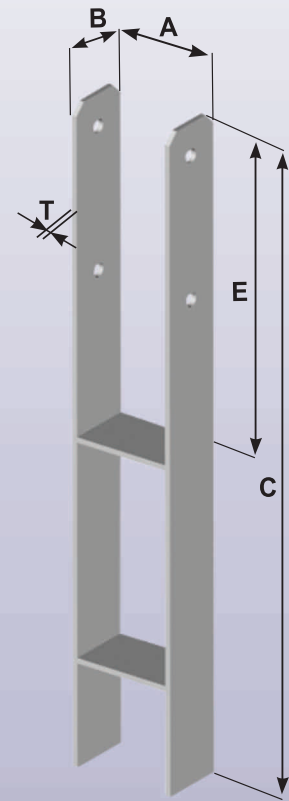
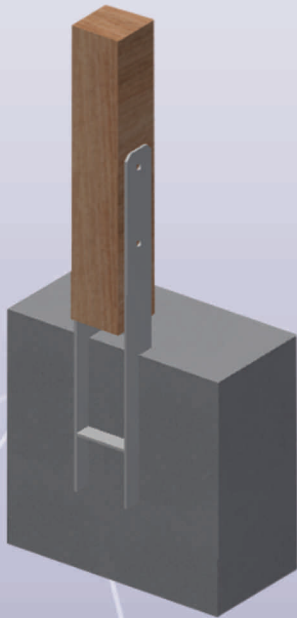

12 - 53 ANCHOR ELEMENT BV/KP

Dimension	A	B	C	E	T
	90	60	600	300	5

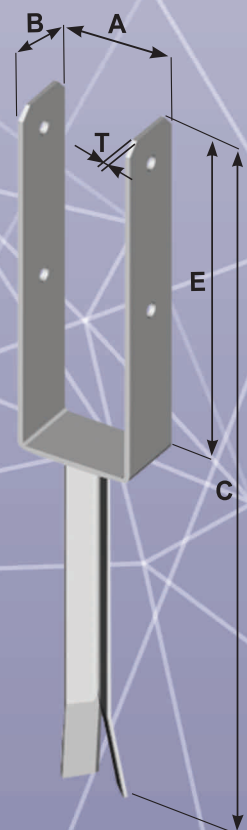

ANCHOR ELEMENT BV/KP 12 - 54

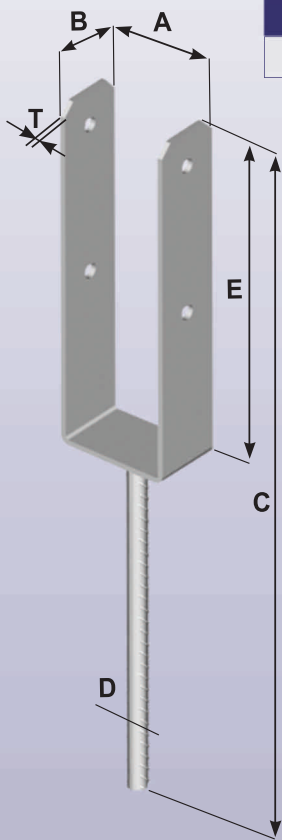

Dimension	A	B	C	D	E	T
	90	60	600	16	300	5

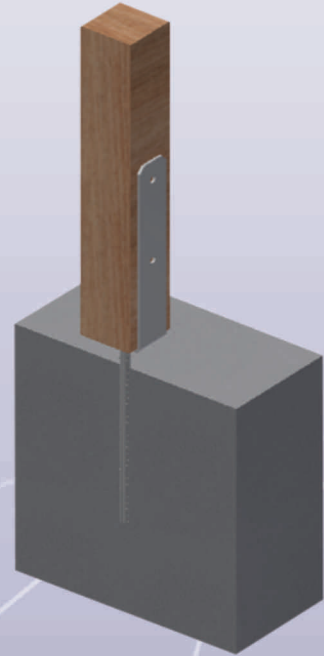

ANCHOR ELEMENT BV/KP 12 - 55

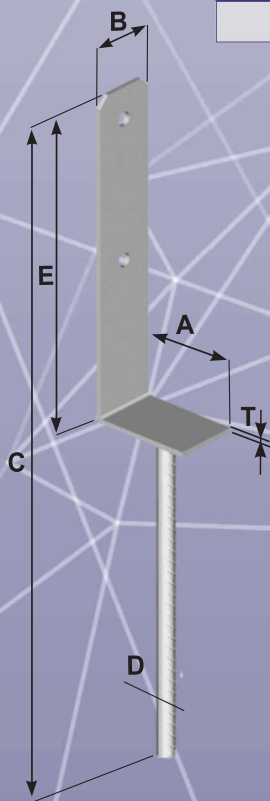

Dimension	A	B	C	D	E	T
	90	60	600	16	300	5

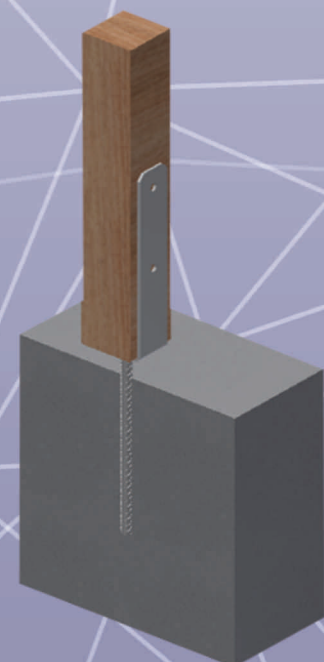

12 - 60 ANCHOR ELEMENT BV/KP

Dimension	A	B	C	D	T
60	60	150	200	60	5
70	70	160	200	60	5
80	80	170	200	60	5
90	90	180	200	60	5
100	100	190	200	60	5
120	120	210	200	60	5
140	140	230	200	60	5

ordering example :
anchor element BV/KP 12-60/A

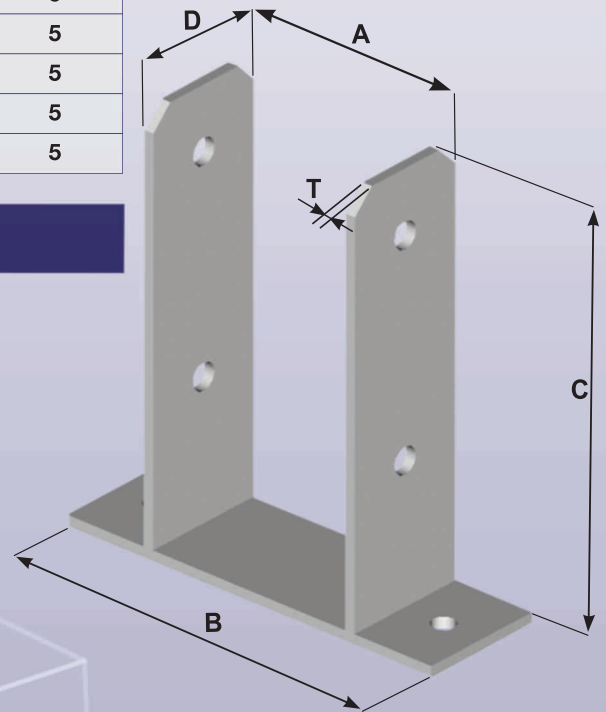
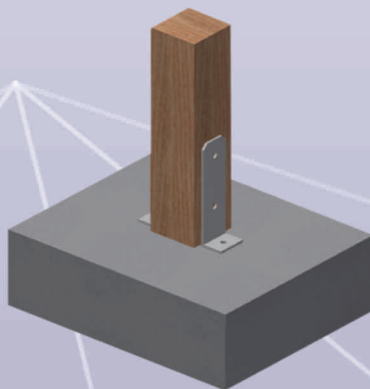

12 - 61 ANCHOR ELEMENT BV/KP

Dimension	A	B	C	D	T
60	60	150	200	60	5
70	70	160	200	60	5
80	80	170	200	60	5
90	90	180	200	60	5
100	100	190	200	60	5
120	120	210	200	60	5
140	140	230	200	60	5

ordering example :
anchor element BV/KP 12-61/A

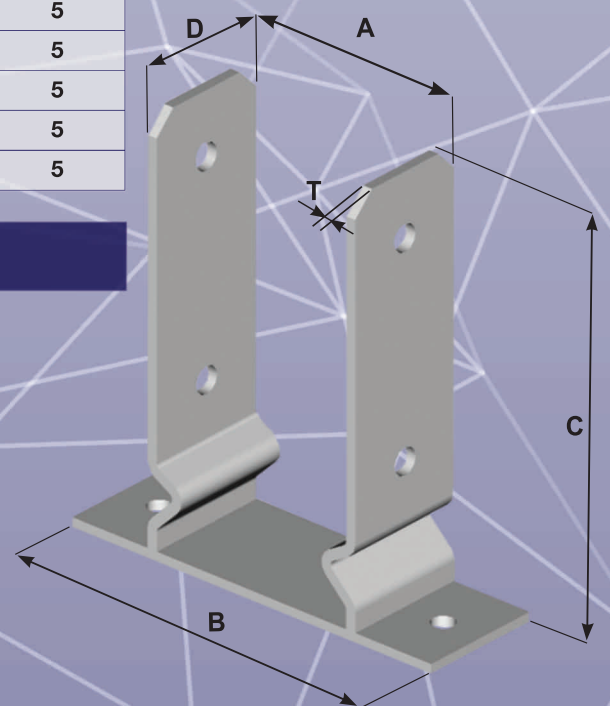
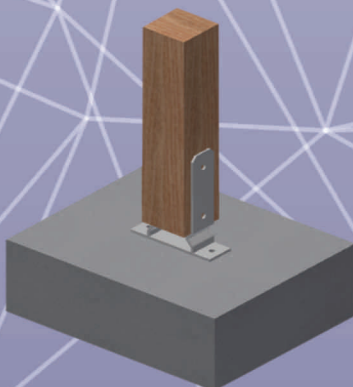

ANCHOR ELEMENT BV/KP 12 - 62

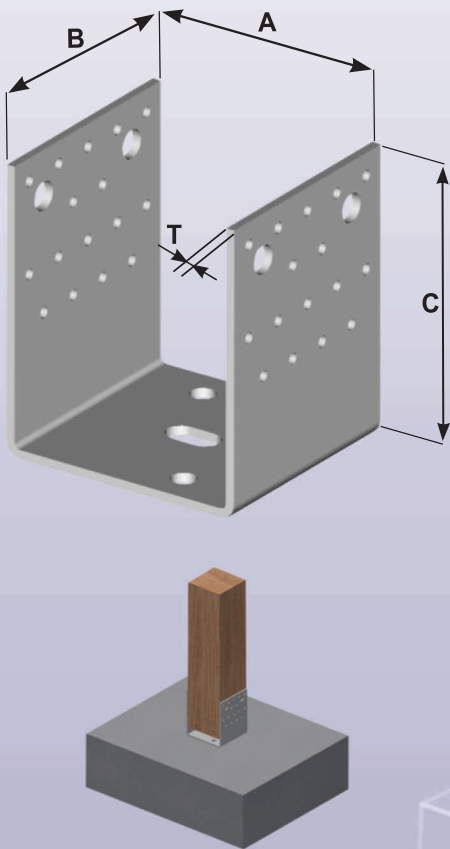

Dimension	A	B	C	T
60x60	61	60	125	4
60x80	61	80	125	4
70x60	71	60	125	4
70x80	71	80	125	4
80x60	81	60	125	4
80x80	81	80	125	4
80x100	81	100	125	4
90x80	91	80	125	4
90x100	91	100	125	4
90x120	91	120	125	4
100x80	101	80	125	4
100x100	101	100	125	4
100x120	101	120	125	4
120x100	121	100	125	4
120x120	121	120	125	4
140x100	141	100	125	4
140x120	141	120	125	4

ordering example :
anchor element BV/KP 12-62/AxB

ANCHOR ELEMENT BV/KP 12 - 63

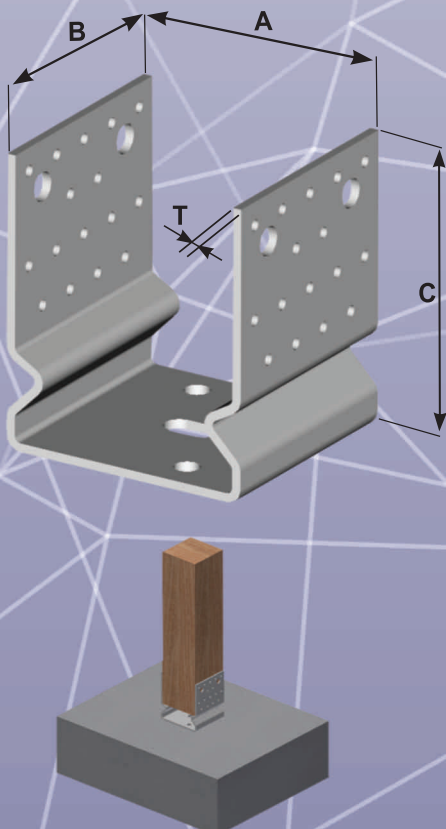

Dimension	A	B	C	T
60x60	61	60	125	4
60x80	61	80	125	4
70x60	71	60	125	4
70x80	71	80	125	4
80x60	81	60	125	4
80x80	81	80	125	4
80x100	81	100	125	4
90x80	91	80	125	4
90x100	91	100	125	4
90x120	91	120	125	4
100x80	101	80	125	4
100x100	101	100	125	4
100x120	101	120	125	4
120x100	121	100	125	4
120x120	121	120	125	4
140x100	141	100	125	4
140x120	141	120	125	4

ordering example :
anchor element BV/KP 12-63/AxB

13 - 01 BULLDOG DOWEL 50/17

Dimension	L	d	H	T
	50	17	13	1

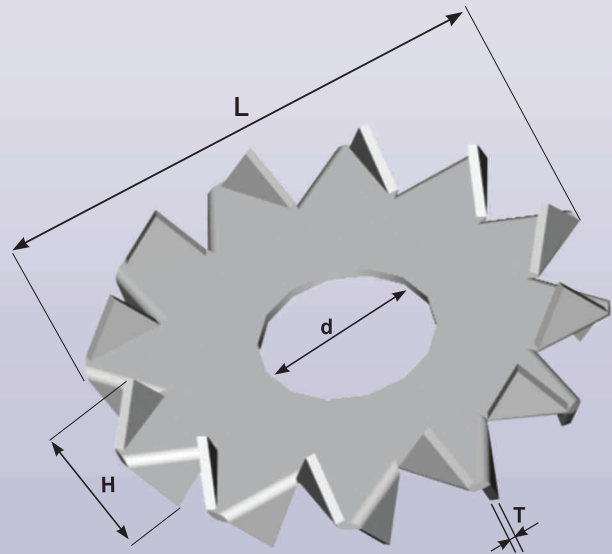
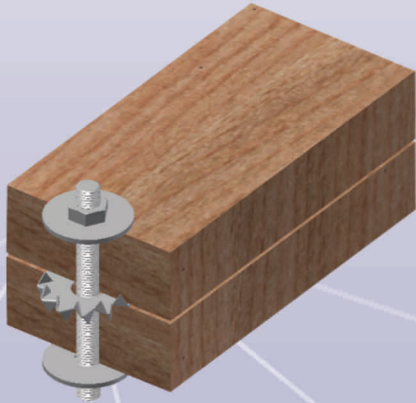

13 - 02 BULLDOG DOWEL 75/26

Dimension	L	d	H	T
	75	26	19,5	1.25

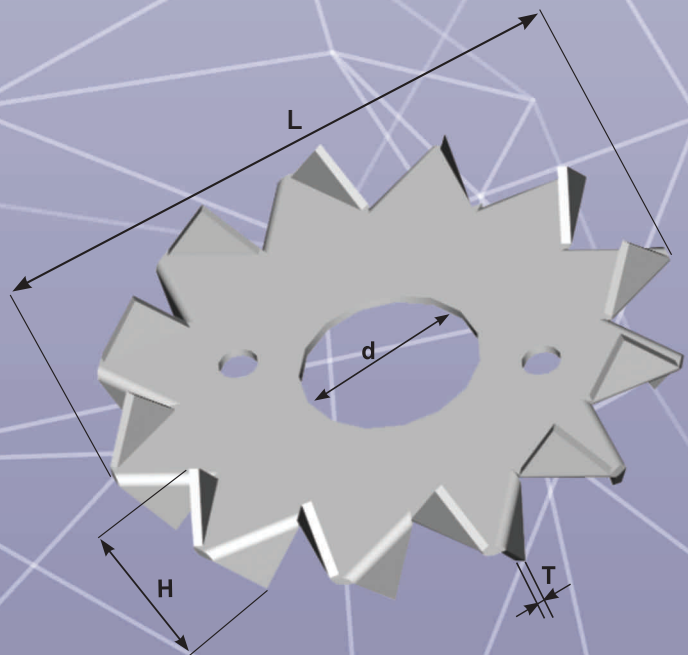
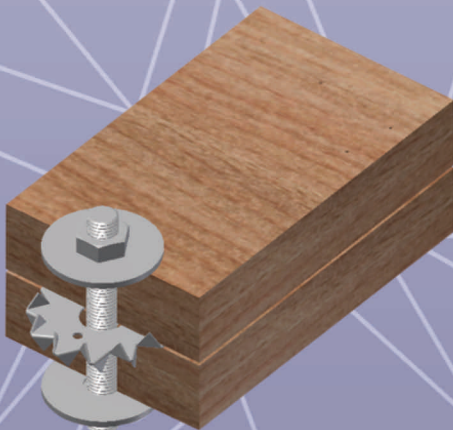

BULLDOG DOWEL 95/36 13 - 03

Dimension	L	d	H	T
	95	36	24	1,5

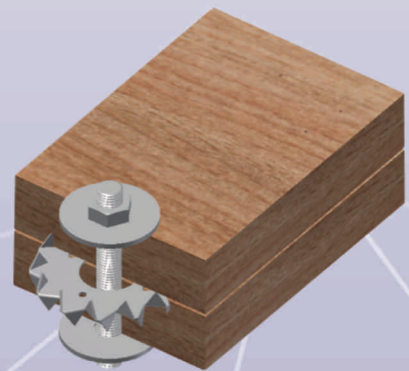
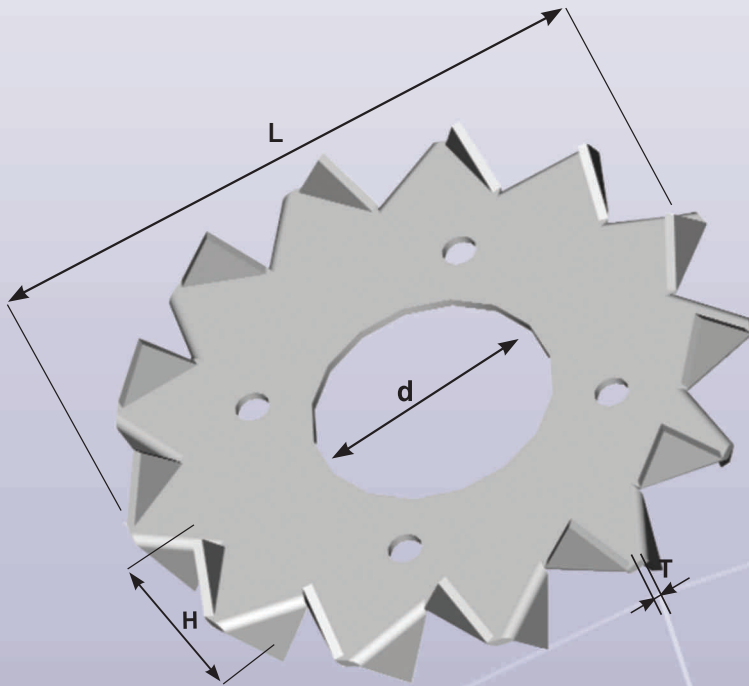

SNUG OF THE WOODEN PILLAR BV/P 14 - 01

Dimension	A	B	D	H	T
	110	110	M24	200	4
	110	110	M24	250	4
	110	110	M24	330	4
	80	110	M24	200	4
	80	110	M24	250	4
	80	110	M24	330	4

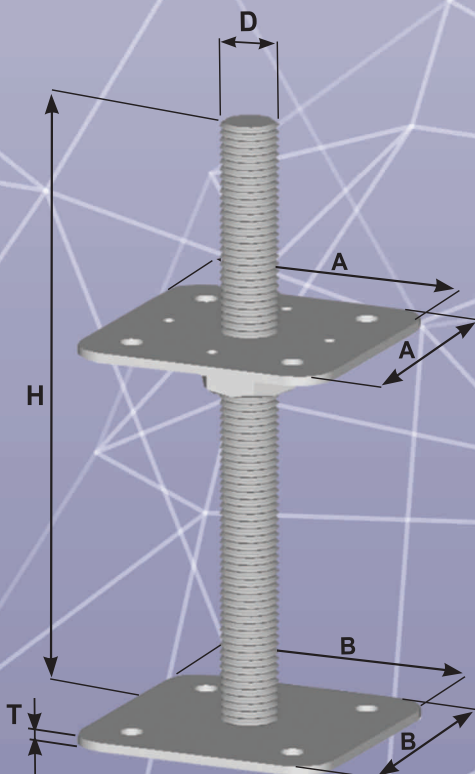

variation : welded nut, two rotary nuts
 ordering example : snug of the wooden pillar BV/P 14-01/H - variation



14 - 02 ANCHOR COLUMN SHOE BV/P

Dimension	A	B	C	D	E	T
60x60	61	60	125	16	250	4
60x80	61	80	125	16	250	4
70x60	71	60	125	16	250	4
70x80	71	80	125	16	250	4
80x60	81	60	125	16	250	4
80x80	81	80	125	16	250	4
80x100	81	100	125	16	250	4
90x80	91	80	125	16	250	4
90x100	91	100	125	16	250	4
90x120	91	120	125	16	250	4
100x80	101	80	125	16	250	4
100x100	101	100	125	16	250	4
100x120	101	120	125	20	250	4
120x100	121	100	125	20	250	4
120x120	121	120	125	20	250	4
140x100	141	100	125	20	250	4
140x120	141	120	125	20	250	4

ordering example :
anchor column shoe BV/P 14-02/AxB

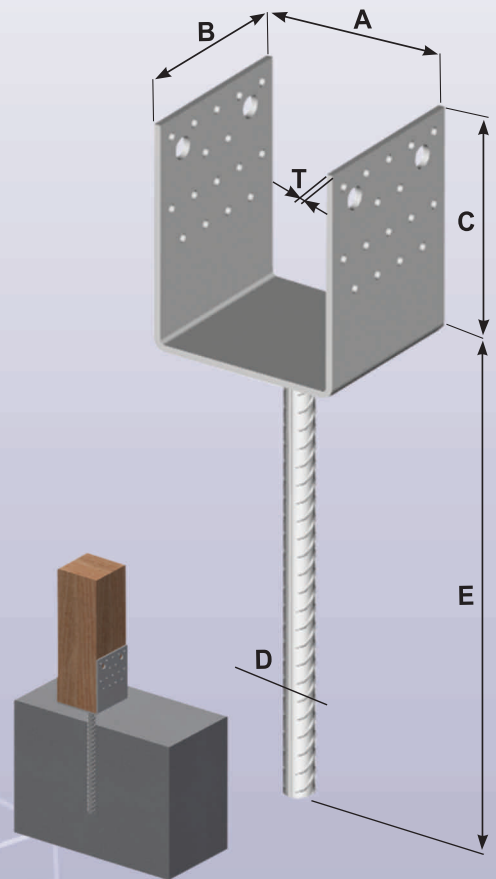

14 - 03 ANCHOR COLUMN SHOE BV/P

Dimension	A	B	C	D	E	T
80x80	81	80	125	16	250	4
100x80	101	80	125	16	250	4
100x100	101	100	125	16	250	4
120x100	121	100	125	20	250	4
120x120	121	120	125	20	250	4

ordering example :
anchor column shoe BV/P 14-03/AxB

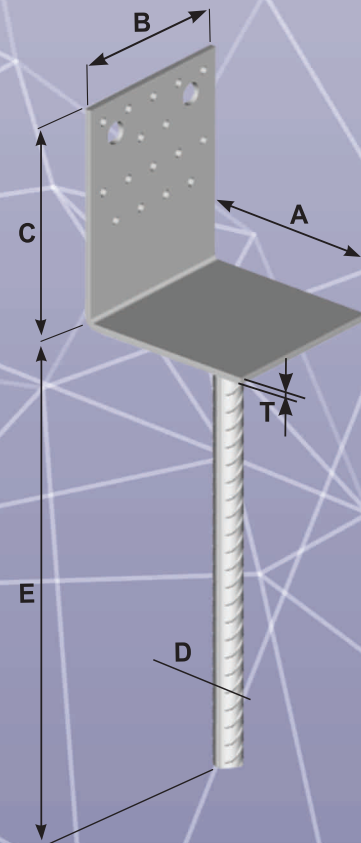
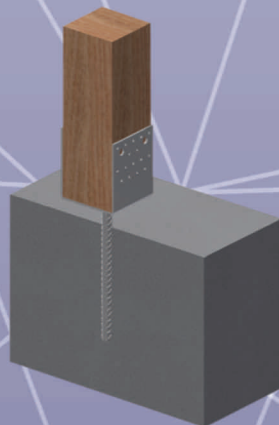

ANCHOR COLUMN SHOE BV/P 14 - 04

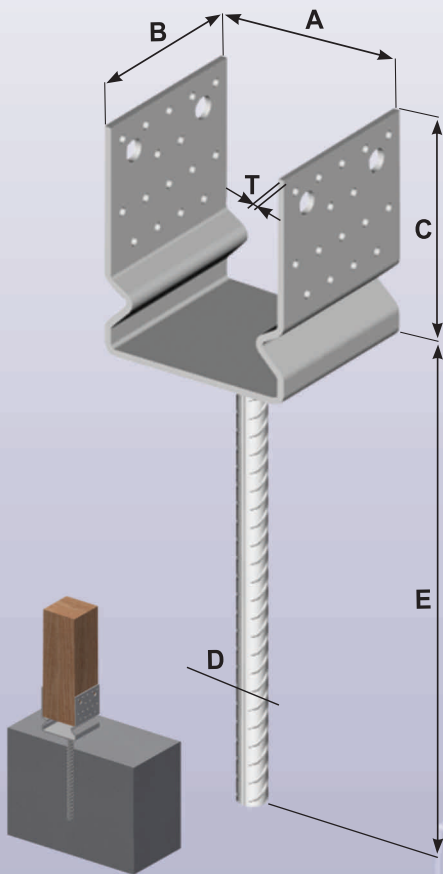

Dimension	A	B	C	D	E	T
60x60	61	60	125	16	250	4
60x80	61	80	125	16	250	4
70x60	71	60	125	16	250	4
70x80	71	80	125	16	250	4
80x60	81	60	125	16	250	4
80x80	81	80	125	16	250	4
80x100	81	100	125	16	250	4
90x80	91	80	125	16	250	4
90x100	91	100	125	16	250	4
90x120	91	120	125	16	250	4
100x80	101	80	125	16	250	4
100x100	101	100	125	16	250	4
100x120	101	120	125	20	250	4
120x100	121	100	125	20	250	4
120x120	121	120	125	20	250	4
140x100	141	100	125	20	250	4
140x120	141	120	125	20	250	4

ordering example :
anchor column shoe BV/P 14-04/AxB

ANCHOR COLUMN SHOE BV/P 14 - 05

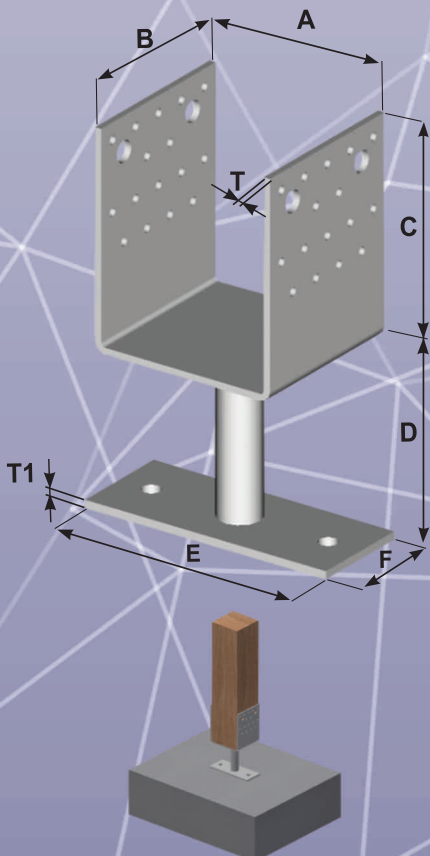

Dimension	A	B	C	D	E	F	T	T1
60x60	61	60	125	100	150	60	4	5
60x80	61	80	125	100	150	60	4	5
70x60	71	60	125	100	150	60	4	5
70x80	71	80	125	100	150	60	4	5
80x60	81	60	125	100	150	60	4	5
80x80	81	80	125	100	150	60	4	5
80x100	81	100	125	100	150	60	4	5
90x80	91	80	125	100	150	60	4	5
90x100	91	100	125	100	150	60	4	5
90x120	91	120	125	100	150	60	4	5
100x80	101	80	125	100	150	60	4	5
100x100	101	100	125	100	150	60	4	5
100x120	101	120	125	100	150	60	4	5
120x100	121	100	125	100	150	60	4	5
120x120	121	120	125	100	150	60	4	5
140x100	141	100	125	100	150	60	4	5
140x120	141	120	125	100	150	60	4	5

ordering example :
anchor column shoe BV/P 14-05/AxB

14 - 06 ANCHOR COLUMN SHOE BV/P

Dimension	A	B	C	D	E	F	T	T1
60x60	61	60	125	100	150	60	4	5
60x80	61	80	125	100	150	60	4	5
70x60	71	60	125	100	150	60	4	5
70x80	71	80	125	100	150	60	4	5
80x60	81	60	125	100	150	60	4	5
80x80	81	80	125	100	150	60	4	5
80x100	81	100	125	100	150	60	4	5
90x80	91	80	125	100	150	60	4	5
90x100	91	100	125	100	150	60	4	5
90x120	91	120	125	100	150	60	4	5
100x80	101	80	125	100	150	60	4	5
100x100	101	100	125	100	150	60	4	5
100x120	101	120	125	100	150	60	4	5
120x100	121	100	125	100	150	60	4	5
120x120	121	120	125	100	150	60	4	5
140x100	141	100	125	100	150	60	4	5
140x120	141	120	125	100	150	60	4	5

ordering example :
anchor column shoe BV/P 14-06/AxB

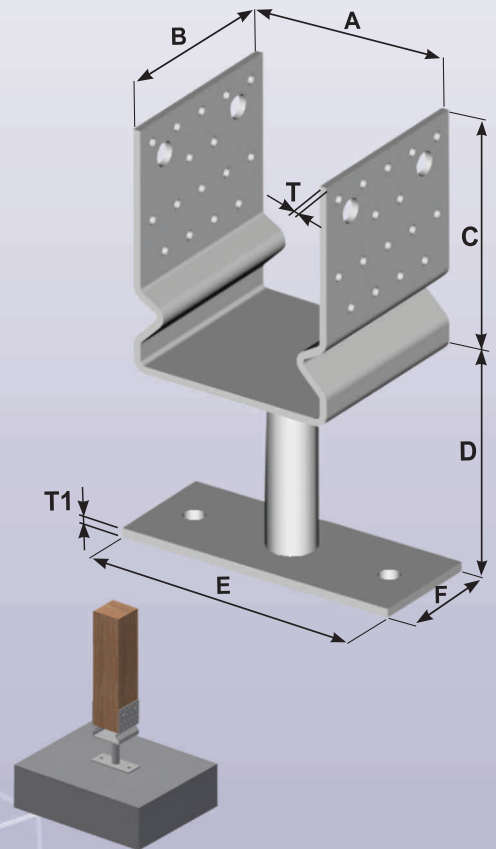

14 - 07 ANCHOR COLUMN SHOE BV/P

Dimension	A	B	C	D	H	E	T
60x60	61	60	125	M24	200	110	4
60x80	61	80	125	M24	200	110	4
70x60	71	60	125	M24	200	110	4
70x80	71	80	125	M24	200	110	4
80x60	81	60	125	M24	200	110	4
80x80	81	80	125	M24	200	110	4
80x100	81	100	125	M24	200	110	4
90x80	91	80	125	M24	200	110	4
90x100	91	100	125	M24	200	110	4
90x120	91	120	125	M24	200	110	4
100x80	101	80	125	M24	200	110	4
100x100	101	100	125	M24	200	110	4
100x120	101	120	125	M24	200	110	4
120x100	121	100	125	M24	200	110	4
120x120	121	120	125	M24	200	110	4
140x100	141	100	125	M24	200	110	4
140x120	141	120	125	M24	200	110	4

ordering example :
anchor column shoe BV/P 14-07/AxB

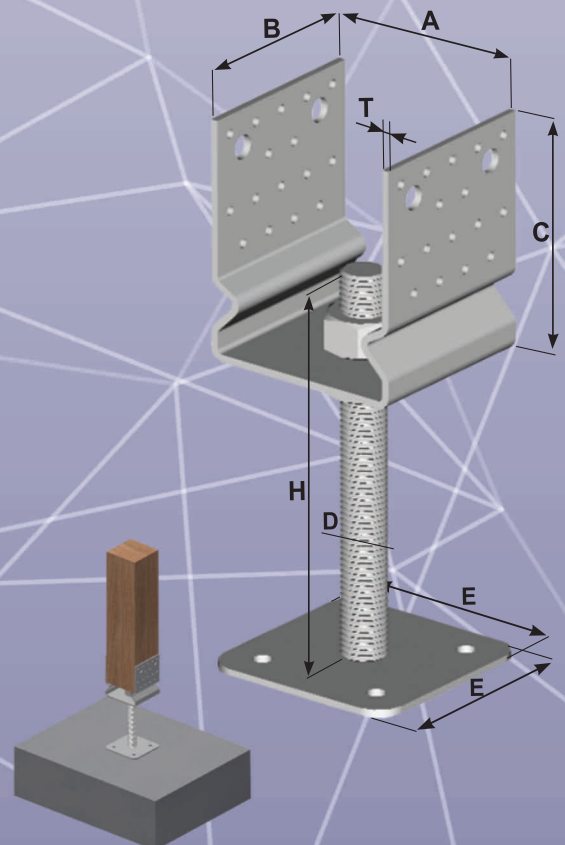

ANCHOR COLUMN SHOE BV/P 14 - 08

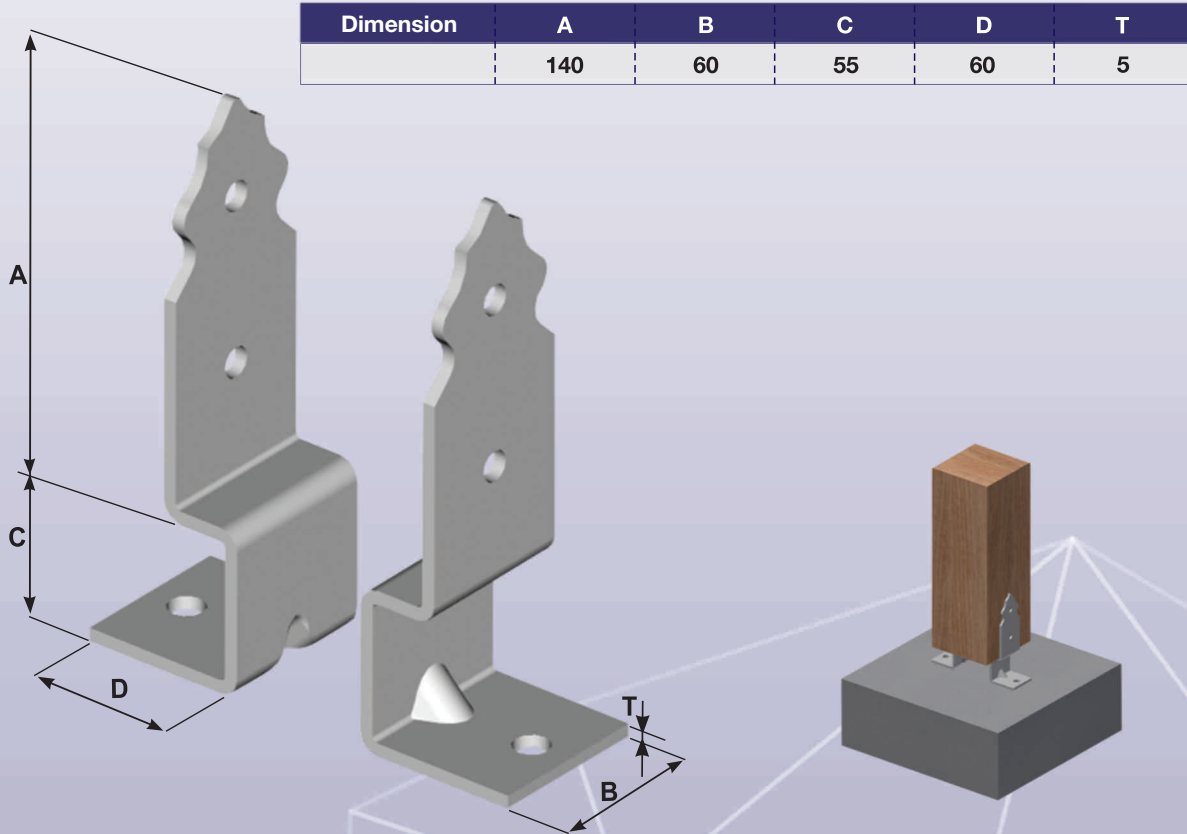

Dimension	A	B	C	D	T
	140	60	55	60	5

COLUMN SHOE OF THE WOODEN PILLAR BV/P 14 - 09

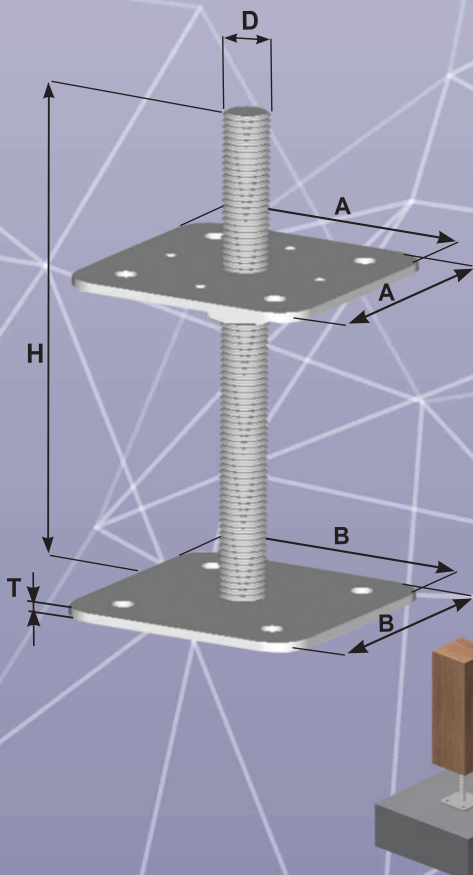

Dimension	A	B	D	H	T
	110	110	M20	165	4
	110	110	M20	200	4
	110	110	M20	250	4
	110	110	M20	330	4
	80	110	M20	165	4
	80	110	M20	200	4
	80	110	M20	250	4
	80	110	M20	330	4
	80	80	M20	165	4
	80	80	M20	200	4
	80	80	M20	250	4
	80	80	M20	330	4

variation : welded nut, two rotary nuts
 ordering example : column shoe of the wooden pillar BV/P 14-09/H - variation

14 - 10 COLUMN SHOE OF THE WOODEN PILLAR BV/P

Dimension	A	B	D	H	T
	80	80	M16	100	4
	80	80	M16	165	4
	80	80	M16	200	4

variation : welded nut, two rotary nuts
 ordering example : column shoe of the wooden pillar BV / P 14-10/H - variation

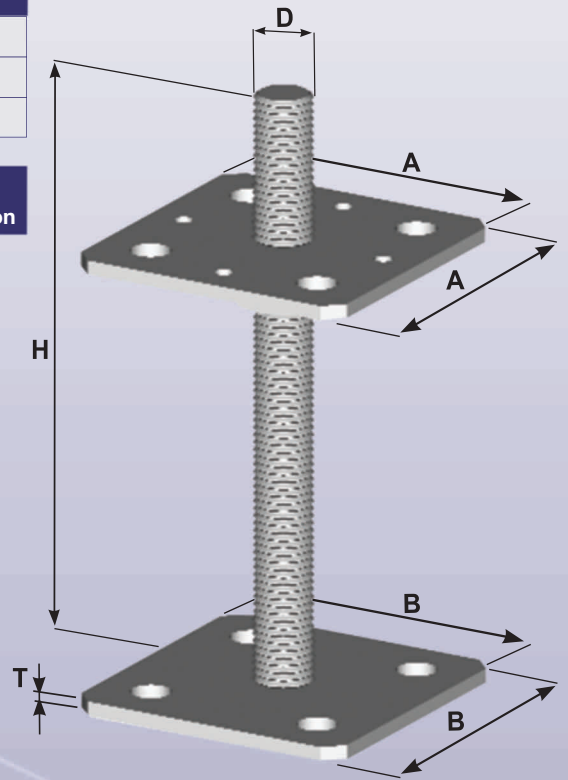
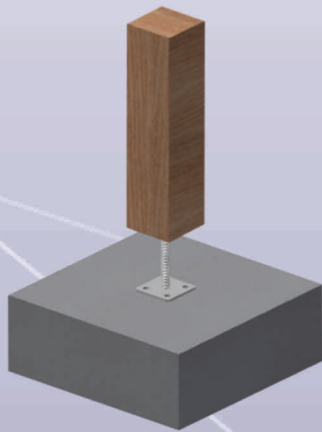

14 - 12 COLUMN SHOE WITH THE SAFETY FUSE BV/P

Dimension	A	B	D	H	T
	110	110	M24	200	4
	110	110	M24	250	4
	110	110	M24	330	4

ordering example :
 column shoe with the safety fuse BV/P 14-12/H

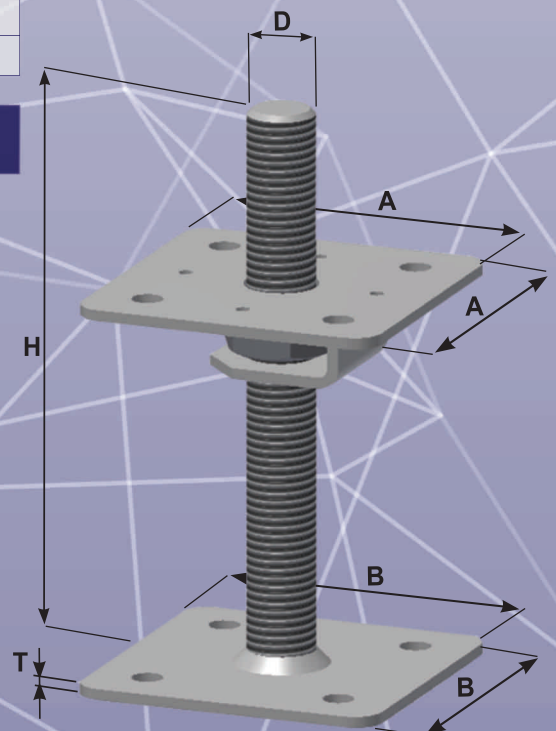

CONVEX NAIL BV/KH

15 - 01

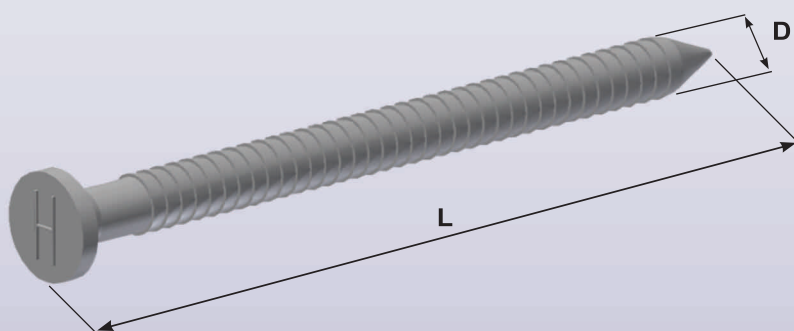

Dimension	D	L
4 x 40	4	40
4 x 50	4	50
4 x 60	4	60
4 x 70	4	70
4 x 80	4	80
4 x 90	4	90

minimum order quantity is 5 kg

THREADED ROD

16 - xx

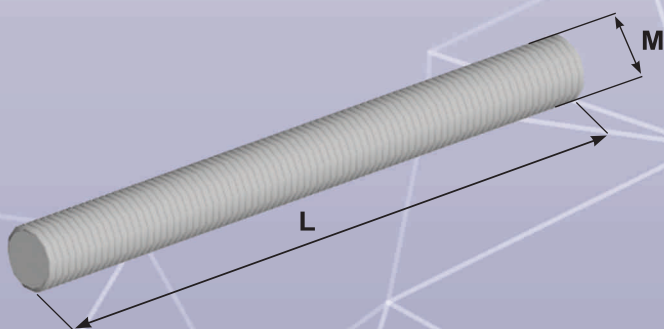

metric thread	L	catalogue number
M8	1000	16 - 04
M10	1000	16 - 05
M12	1000	16 - 06
M16	1000	16 - 07
M20	1000	16 - 08
M24	1000	16 - 09

NUT

17 - xx

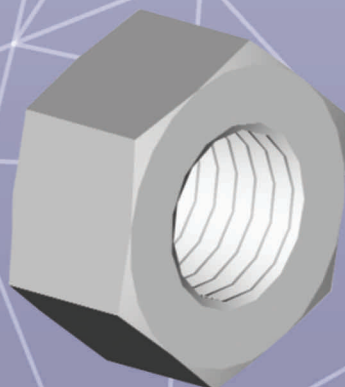

metric thread	catalogue number
M8	17 - 04
M10	17 - 05
M12	17 - 06
M16	17 - 07
M20	17 - 08
M24	17 - 09

18 - xx WASHER FOR WOODEN CONSTRUCTIONS

d	D	T	catalogue number
9	28	3	18 - 04
11	34	3	18 - 05
14	45	4	18 - 06
18	58	5	18 - 07
18	68	5	18 - 07/A
22	68	5	18 - 08
26	92	5	18 - 09

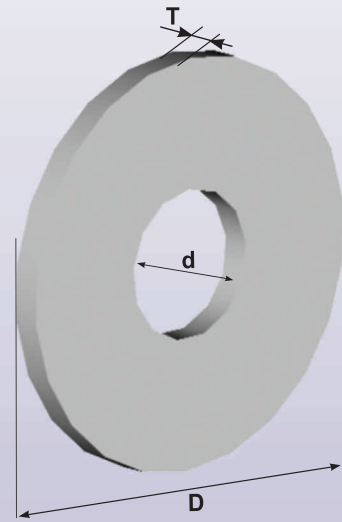

19 - 01 SQUARE WASHER

Dimension	A	B	T	D
	40	20	8	11
	40	20	8	13

ordering example : square washer 19-01/D

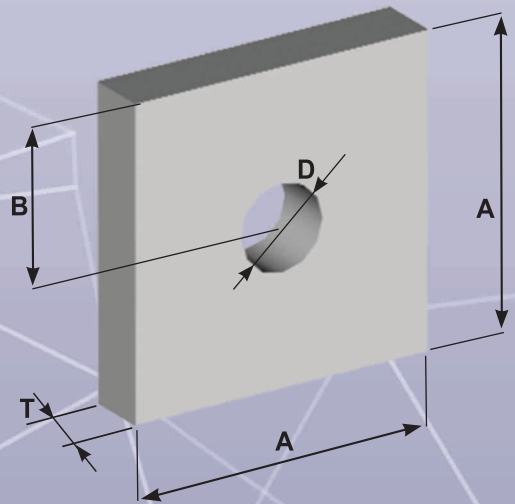

19 - 02 SQUARE WASHER

Dimension	A	B	T	D
	40	15	8	11
	40	15	8	13

ordering example : square washer 19-02/D

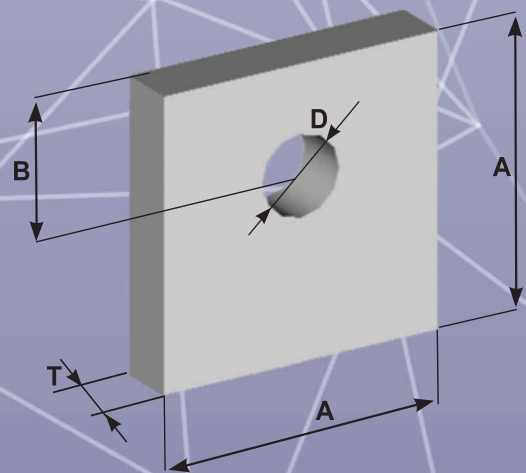

HINGE BV/Z - I 30 - 01

Dimension	A	B	C	D	T
	90	50	35	207	2,5

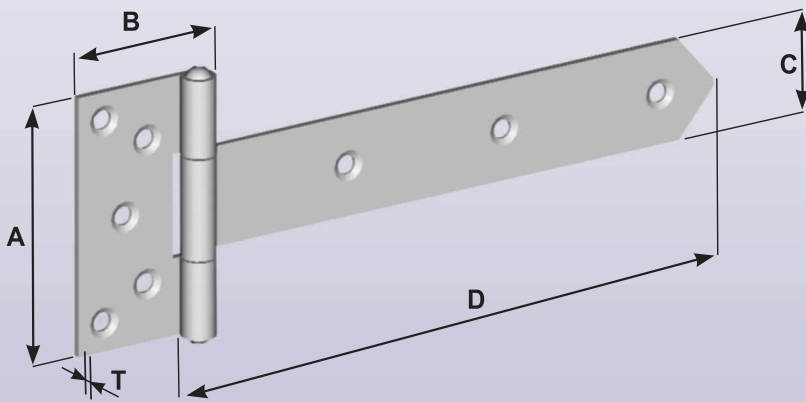

HINGE BV/Z - II 30 - 02

Dimension	A	B	C	D	T
	90	50	35	207	2,5

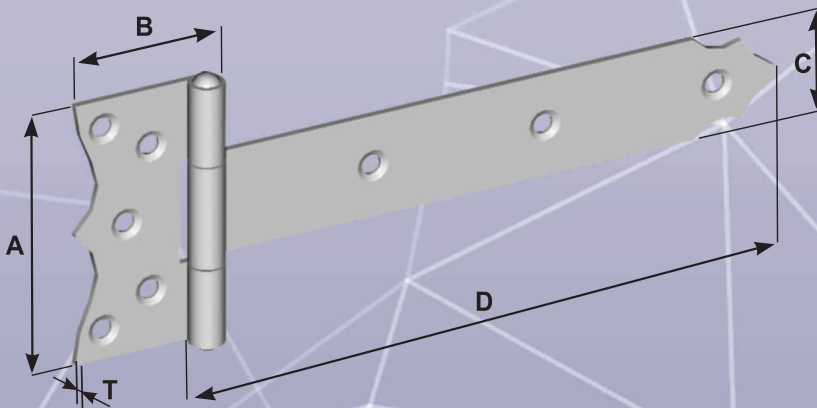

HINGE BV/Z 30 - 03

Dimension	A	B	C
	49	100	15

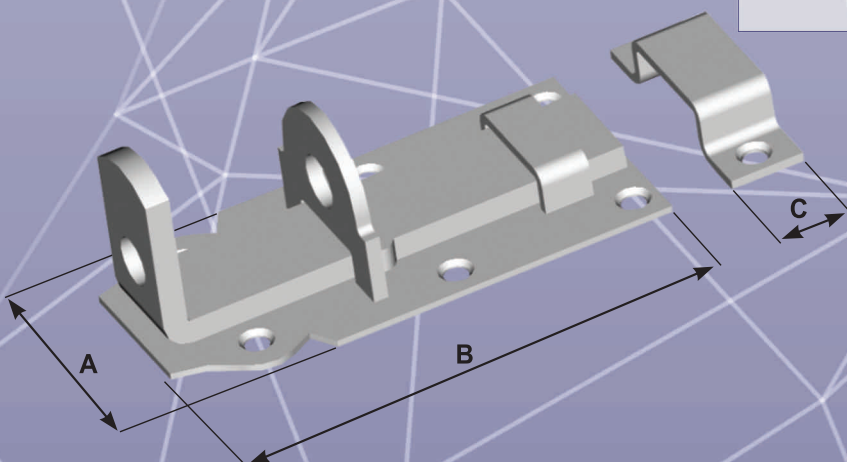

30 - 04 HINGE BV/Z - I

Dimension	A	B	C	D	T
	90	50	35	157	2,5

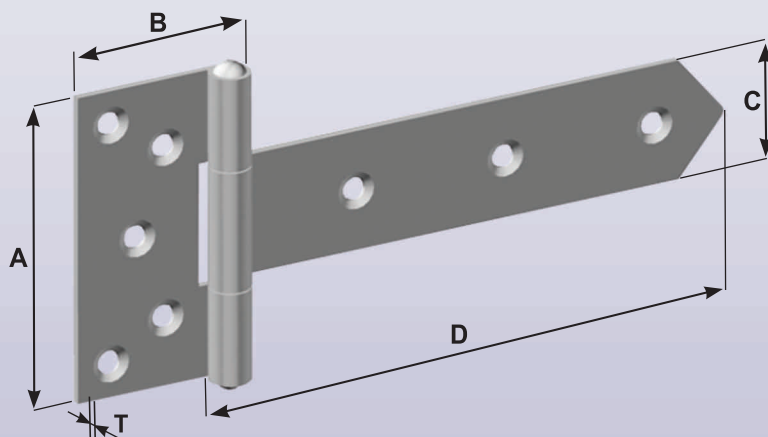

30 - 05 HINGE BV/Z - II

Dimension	A	B	C	D	T
	90	50	35	157	2,5

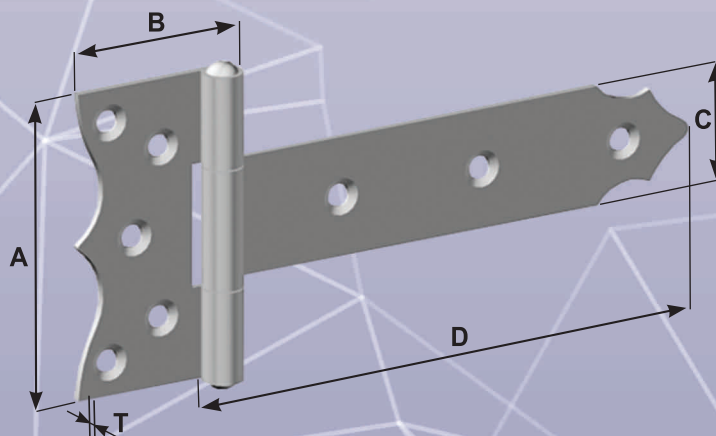

30 - 06 HINGE BV/Z - I

Dimension	A	B	C	D	T
	90	50	35	107	2,5

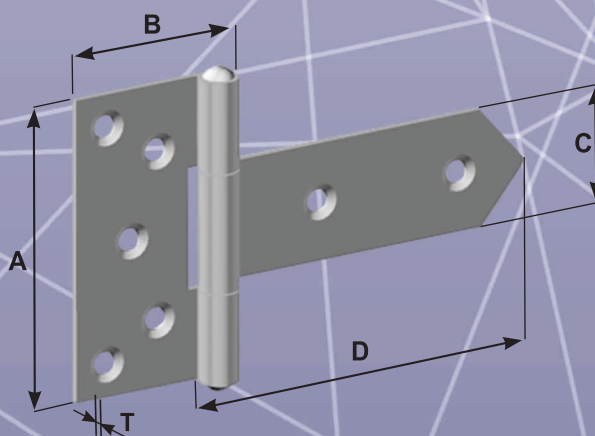

HINGE BV/Z - II 30 - 07

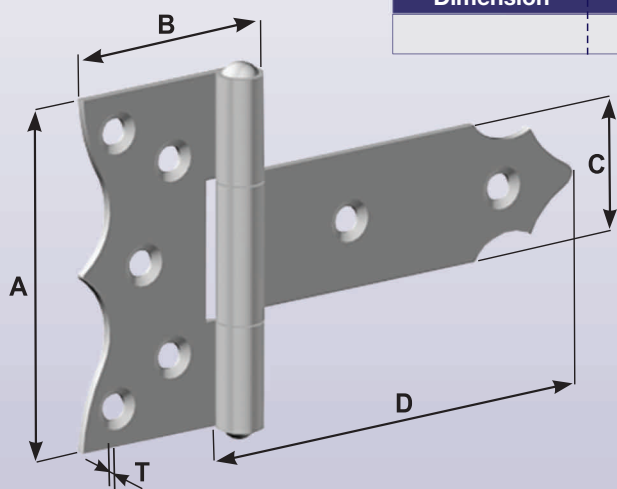

Dimension	A	B	C	D	T
	90	50	35	107	2,5

ANGLE BV/Ú 31 - 01

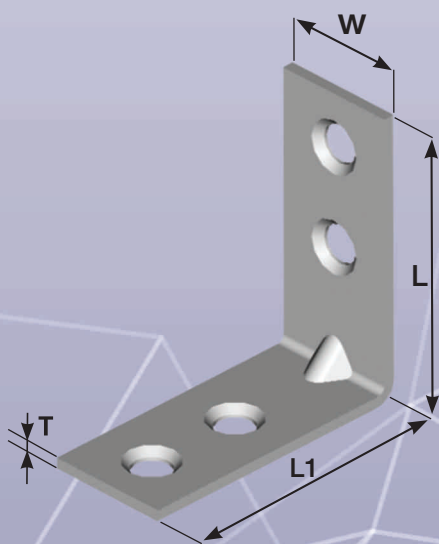

Dimension	W	L	L1	T
	16	37	37	1,5

ANGLE BV/Ú 31 - 03

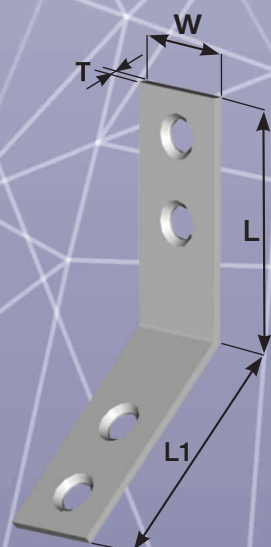

Dimension	W	L	L1	T
	16	36	36	1,5

Certificates

TECHNICKÝ A ZKUŠEBNÍ ÚSTAV STAVEBNÍ PRAHA, s.p.
Technical and Test Institute for Construction Prague
Akreditovaná zkušební laboratoř, Autorizovaná osoba, Notifikovaná osoba, Oznamovací úřad, Společně pro technické posouzení, Certifikační orgán, Inspekční orgán / Accredited Testing Laboratory, Authorized Body, Notified Body, Technical Assessment Body, Certification Body, Inspection Body - Provozník 811/06a, 100 00 Praha 9 - PRAHA, Czech Republic

Notified Body 1020

**CERTIFICATE OF CONFORMITY
 OF THE FACTORY PRODUCTION CONTROL**
 No. 1020 – CPR – 010033626

In compliance with Regulation (EU) No 305/2011 of the European Parliament and of the Council of 9 March 2011 (the Construction Products Regulation or CPR), this certificate applies to the construction product:

Nailing plates
 connecting plates: BV/D5 03-01; BV/D5 03-08
 clutches: 8641462 03-31; 8641774 03-32; 9642004 03-33
 Wind brace band: BV/ZP 10-01; BV/ZP 10-02; BV/ZP 10-03; BV/ZP 10-04; BV/ZP 10-05; BV/ZP 10-07
 Nailings plates are designed for connecting elements of timber structures. Nailings plates shall be manufactured from mild plate or strip of steel S235GD+Z275.

placed on the market under the name or trade mark of
BOVA Břežnice spol. s r.o.
 282 72 Břežnice, Za nádražím 472, IČ 42728191
 and produced in the manufacturing plant(s)
BOVA Břežnice spol. s r.o.
 282 72 Břežnice, Za nádražím 472, IČ 42728191

This certificate attests that all provisions concerning the assessment and verification of constancy of performance described in Annex ZA of the standard(s)
EN 14545:2008
 under system 2+ are applied and that
the factory production control is assessed to be in conformity with the applicable requirements.

This certificate was first issued on 15.7.2014 and will remain valid as long as neither the harmonised standard, the construction product, the AVCP methods nor the manufacturing conditions in the plant are modified significantly, unless suspended or withdrawn by the notified factory production control certification body.

The stamp of the Notified Body 1020
 Praha, 15. August, 2014

 Ing. Iveta Jirouzková
 Deputy manager of the Notified Body

TECHNICKÝ A ZKUŠEBNÍ ÚSTAV STAVEBNÍ PRAHA, s.p.
Technical and Test Institute for Construction Prague
Akreditovaná zkušební laboratoř, Autorizovaná osoba, Notifikovaná osoba, Oznamovací úřad, Společně pro technické posouzení, Certifikační orgán, Inspekční orgán / Accredited Testing Laboratory, Authorized Body, Notified Body, Technical Assessment Body, Certification Body, Inspection Body - Provozník 811/06a, 100 00 Praha 9 - PRAHA, Czech Republic

Notified Body 1020

**CERTIFICATE OF CONFORMITY
 OF THE FACTORY PRODUCTION CONTROL**
 No. 1020 – CPR – 010036940

In compliance with Regulation (EU) No 305/2011 of the European Parliament and of the Council of 9 March 2011 (the Construction Products Regulation or CPR), this certificate applies to the construction product:

Connectors for timber
 Type: C1: 095 mm-1301; 076 mm-1302; 095 mm-1302
 Connectors according to EN 812 are intended for the connection of wooden structures.
 They are made of sheet steel DX51D+Z275

placed on the market under the name or trade mark of
BOVA Břežnice spol. s r.o.
 282 72 Břežnice, Za nádražím 472, IČ 42728191
 and produced in the manufacturing plant(s)
BOVA Břežnice spol. s r.o.
 282 72 Břežnice, Za nádražím 472, IČ 42728191

This certificate attests that all provisions concerning the assessment and verification of constancy of performance described in Annex ZA of the standard(s)
EN 14545:2008
 under system 2+ are applied and that
the factory production control is assessed to be in conformity with the applicable requirements.

This certificate will remain valid as long as neither the harmonised standard, the construction product, the AVCP methods nor the manufacturing conditions in the plant are modified significantly, unless suspended or withdrawn by the notified factory production control certification body.

The stamp of the Notified Body 1020
 Prague, 3 November 2016

 Ing. Iveta Jirouzková
 Deputy manager of the Notified Body

TECHNICKÝ A ZKUŠEBNÍ ÚSTAV STAVEBNÍ PRAHA, s.p.
Technical and Test Institute for Construction Prague
Akreditovaná zkušební laboratoř, Autorizovaná osoba, Notifikovaná osoba, Oznamovací úřad, Společně pro technické posouzení, Certifikační orgán, Inspekční orgán / Accredited Testing Laboratory, Authorized Body, Notified Body, Technical Assessment Body, Certification Body, Inspection Body - Provozník 811/06a, 100 00 Praha 9 - PRAHA, Czech Republic

Notified Body 1020

**CERTIFICATE OF CONFORMITY
 OF FACTORY PRODUCTION CONTROL**
 No. 1020 – CPR – 010028388

In compliance with Regulation 305/2011/EU of the European Parliament and of the Council of 9 March 2011 (the Construction Products Regulation or CPR), this certificate applies to the construction product:

Punched metal plate fasteners for timber BV11; BV15; BV16; BV20
 For use in load bearing timber structures according to EN1995-1-1 Eurokode 5: Design of timber structures - Part 1-1: General Common rules for buildings

produced by or for
BOVA Břežnice, spol. s r.o.
 Břežnice, Za nádražím 472, IČ 42728191
 and produced in the manufacturing plant(s)
Břežnice, Za nádražím 472

This certificate attests that all provisions concerning the assessment and verification of constancy of performance described in Annex ZA of the standard
EN 14545:2008
 under system 2+ are applied and that
the factory production control fulfills all the prescribed requirements set out above.

This certificate was first issued on 6 May 2010 under CPD and will remain valid as long as the test methods and/or factory production control requirements included in the harmonised standard, used to assess the performance of the declared characteristics, do not change, and the product, and the manufacturing conditions in the plant are not modified significantly.

The stamp of the Notified Body 1020
 Prague, 11 November 2013

 Ing. Iveta Jirouzková
 Deputy manager of the Notified Body

TECHNICKÝ A ZKUŠEBNÍ ÚSTAV STAVEBNÍ PRAHA, s.p.
Technical and Test Institute for Construction Prague, SOE
Akreditovaná zkušební laboratoř, Autorizovaná osoba, Notifikovaná osoba, Oznamovací úřad, Společně pro technické posouzení, Certifikační orgán, Inspekční orgán / Accredited Testing Laboratory, Authorized Body, Notified Body, Technical Assessment Body, Certification Body, Inspection Body - Provozník 811/06a, 100 00 Praha 9 - PRAHA, Czech Republic

Notified Body 1020

**CERTIFICATE OF CONFORMITY
 OF THE FACTORY PRODUCTION CONTROL**
 No. 1020 – CPR – 010-040973

In compliance with Regulation (EU) No 305/2011 of the European Parliament and of the Council of 9 March 2011 (the Construction Products Regulation or CPR), this certificate applies to the construction product:

Beam Hangers
 BHV – 40 11-21; BHV – 60 11-22; BHV – 80 11-23;
 BHV – 70 11-24; BHV – 90 11-25; BHV – 90 11-26;
 BHV – 100 11-27; BHV – 120 11-28; BHV – 140 11-31;
 BHV 11-40; BHV 11-41;

placed on the market under the name or trade mark of
BOVA Břežnice spol. s r.o.
 282 72 Břežnice, Za nádražím 472, IČ 42728191
 and produced in the manufacturing plant
BOVA Břežnice spol. s r.o.
 282 72 Břežnice, Za nádražím 472, IČ 42728191

This certificate attests that all provisions concerning the assessment and verification of constancy of performance described in
ETA 17/0598, issued on 07/01/2019
 and
ETAG 015, November 2012 (used as EAD)
 under system 2+ are applied and that
the factory production control is assessed to be in conformity with the applicable requirements.

This certificate was first issued on 19. 3. 2019 and will remain valid according CPR as long as neither the ETA, the EAD, the construction product, the AVCP methods, nor the manufacturing conditions in the plant are modified significantly, unless suspended or withdrawn by the notified factory production control certification body.

The stamp of the Notified Body 1020
 Prague, 19 March, 2019

 Ing. Iveta Jirouzková
 Deputy manager of the Notified Body

TECHNICKÝ A ZKUŠEBNÍ ÚSTAV STAVEBNÍ PRAHA, s.p.
Technical and Test Institute for Construction Prague, SOE
Akreditovaná zkušební laboratoř, Autorizovaná osoba, Notifikovaná osoba, Oznamovací úřad, Společně pro technické posouzení, Certifikační orgán, Inspekční orgán / Accredited Testing Laboratory, Authorized Body, Notified Body, Technical Assessment Body, Certification Body, Inspection Body - Provozník 811/06a, 100 00 Praha 9 - PRAHA, Czech Republic

Notified Body 1020

**CERTIFICATE OF CONFORMITY
 OF THE FACTORY PRODUCTION CONTROL**
 No. 1020 – CPR – 010-034303

In compliance with Regulation (EU) No 305/2011 of the European Parliament and of the Council of 9 March 2011 (the Construction Products Regulation or CPR), this certificate applies to the construction product:

Three – dimensional nailing plates
 Angle Brackets: BVU – 05-21, BVU – 05-22 and BVU – 05-23, basic sizes in a row – 55 x 70 x 70 x 2, 65 x 90 x 2,5 and 90 x 100 x 3 mm, cold formed.
 Angle Brackets and Parlin Tiles: BVU 65x70x70x2,21BVU; BVU 65x90x90x0,5,23BVU; BVU 90x100x100x0,5,23BVU; BVU – 05-01 (17types); BVU – 05-01 (8types), BVU – 05-17/88; BVU – 05-18/20; BVU – 05-19/80

placed on the market under the name or trade mark of
BOVA Břežnice spol. s r.o.
 282 72 Břežnice, Za nádražím 472, IČ 42728191
 and produced in the manufacturing plant
BOVA Břežnice spol. s r.o.
 282 72 Břežnice, Za nádražím 472

This certificate attests that all provisions concerning the assessment and verification of constancy of performance described in
ETA 14/0327, issued on 25/09/2014
ETA 16/0774, issued on 24/07/2017
 and
ETAG 015, November 2012 (used as EAD)
 under system 2+ are applied and that
the factory production control is assessed to be in conformity with the applicable requirements.

This certificate was first issued on 16 December 2014 and will remain valid as long as neither the ETA, the EAD, the construction product, the AVCP methods, nor the manufacturing conditions in the plant are modified significantly, unless suspended or withdrawn by the notified factory production control certification body.

The stamp of the Notified Body 1020
 Prague, 26 October, 2017

 Ing. Iveta Jirouzková
 Deputy manager of the Notified Body